

# **Service Manual**

**Tektronix**

**TLA 711 Color  
Benchtop Controller**

**070-9778-03**

**CE**

# Service Manual



## TLA 711 Color Benchtop Controller

**070-9778-03**

This document supports module firmware version 1.00 and above.

### **Warning**

The servicing instructions are for use by qualified personnel only. To avoid personal injury, do not perform any servicing unless you are qualified to do so. Refer to all safety summaries prior to performing service.



Copyright © Tektronix, Inc. All rights reserved.

Tektronix products are covered by U.S. and foreign patents, issued and pending. Information in this publication supercedes that in all previously published material. Specifications and price change privileges reserved.

Printed in the U.S.A.

Tektronix, Inc., P.O. Box 1000, Wilsonville, OR 97070-1000

TEKTRONIX and TEK are registered trademarks of Tektronix, Inc.

MagniVu and PowerFlex are registered trademarks of Tektronix, Inc.

## WARRANTY

Tektronix warrants that the products that it manufactures and sells will be free from defects in materials and workmanship for a period of one (1) year from the date of shipment. If a product proves defective during this warranty period, Tektronix, at its option, either will repair the defective product without charge for parts and labor, or will provide a replacement in exchange for the defective product.

In order to obtain service under this warranty, Customer must notify Tektronix of the defect before the expiration of the warranty period and make suitable arrangements for the performance of service. Customer shall be responsible for packaging and shipping the defective product to the service center designated by Tektronix, with shipping charges prepaid. Tektronix shall pay for the return of the product to Customer if the shipment is to a location within the country in which the Tektronix service center is located. Customer shall be responsible for paying all shipping charges, duties, taxes, and any other charges for products returned to any other locations.

This warranty shall not apply to any defect, failure or damage caused by improper use or improper or inadequate maintenance and care. Tektronix shall not be obligated to furnish service under this warranty a) to repair damage resulting from attempts by personnel other than Tektronix representatives to install, repair or service the product; b) to repair damage resulting from improper use or connection to incompatible equipment; c) to repair any damage or malfunction caused by the use of non-Tektronix supplies; or d) to service a product that has been modified or integrated with other products when the effect of such modification or integration increases the time or difficulty of servicing the product.

**THIS WARRANTY IS GIVEN BY TEKTRONIX IN LIEU OF ANY OTHER WARRANTIES, EXPRESS OR IMPLIED. TEKTRONIX AND ITS VENDORS DISCLAIM ANY IMPLIED WARRANTIES OF MERCHANTABILITY OR FITNESS FOR A PARTICULAR PURPOSE. TEKTRONIX' RESPONSIBILITY TO REPAIR OR REPLACE DEFECTIVE PRODUCTS IS THE SOLE AND EXCLUSIVE REMEDY PROVIDED TO THE CUSTOMER FOR BREACH OF THIS WARRANTY. TEKTRONIX AND ITS VENDORS WILL NOT BE LIABLE FOR ANY INDIRECT, SPECIAL, INCIDENTAL, OR CONSEQUENTIAL DAMAGES IRRESPECTIVE OF WHETHER TEKTRONIX OR THE VENDOR HAS ADVANCE NOTICE OF THE POSSIBILITY OF SUCH DAMAGES.**

## TEKTRONIX SERVICE OPTIONS

Tektronix offers the following service options. These options are modular, flexible, and easy to order with your instrument. Designed to ease installation and start up, to support tracking of calibration to requirements of ISO9000, and to provide for extended repair coverage, these options help fix your long-term maintenance costs and eliminate unplanned expenditures. And these options can be converted from service at Tektronix service depots to service on-site (see Option S3), which helps keep downtime to a minimum.

Product installation service <sup>1</sup>	Option IN	Provides initial installation of the product and familiarizes new users with some of its operation features
Three years of calibration services	Option C3	Provides initial Certification on delivery, plus two more annual calibrations from your service center
Test data	Option D3	Provides test data on delivery and when annual calibration services are provided (three total, requires Option C3)
Three years repair coverage	Option R3	Provides three years of repair coverage for the instrument, including displays and accessories sold with the instrument
One year uplift to on-site service <sup>1, 2</sup>	Option S1	Converts the standard one year, "return to depot" warranty to provide service on site for one year
Three year uplift to on-site service <sup>1, 2</sup>	Option S3	Converts any C3, D3, and R3 options purchased to on-site services for three years

Tektronix Service Options are available at the time you order your instrument. Contact your local Tektronix Sales Office for more information.

<sup>1</sup> Availability of installation and on-site services depends on the type of product and may vary by geography.

<sup>2</sup> Uplift options are ordered with the mainframe products and cover individual modules.

# Table of Contents

Preface .....	v
General Safety Summary .....	ix
Service Safety Summary .....	xi
Introduction .....	xiii

## Specifications

Product Description .....	1-1
Characteristics Tables .....	1-1

## Operating Information

Installation .....	2-1
Hardware Interface .....	2-1
Operating System and Application Interface .....	2-6
Diagnostics .....	2-8

## Theory of Operation

Block Level Description .....	3-1
-------------------------------	-----

## Performance Verification

Performance Verification .....	4-1
--------------------------------	-----

## Adjustment Procedures

Adjustment Procedures .....	5-1
-----------------------------	-----

## Maintenance

Related Maintenance Procedures .....	6-1
Preventing ESD .....	6-2
Inspection and Cleaning .....	6-2
<b>Removal and Installation Procedure .....</b>	<b>6-7</b>
Preparation – Please Read .....	6-7
Tools Required .....	6-8
Injector/Ejector Handles .....	6-8
Left Side Cover and Rear Panel .....	6-10
Removing the Benchtop Controller Subassembly .....	6-12
Memory SIMMs .....	6-15
Hard Disk Drive .....	6-16
Floppy Disk Drive .....	6-20

Soldered-On Connectors .....	6-22
<b>Troubleshooting .....</b>	<b>6-23</b>
Service Level .....	6-23
Required Documents .....	6-24
Check for Common Problems .....	6-24
Eliminate Other Problem Sources .....	6-26
Troubleshoot the Benchtop Controller Module .....	6-27
BIOS Error Messages .....	6-35
Adjustment After Repair .....	6-41
<b>Repackaging Instructions .....</b>	<b>6-43</b>

## Options

Options .....	7-1
---------------	-----

## Electrical Parts List

Electrical Parts List .....	8-1
-----------------------------	-----

## Diagrams

Controller Board Block Diagram .....	9-1
Adapter Board Block Diagram .....	9-2

## Replaceable Mechanical Parts

Standard Accessories .....	10-1
Optional Accessories .....	10-2
Parts Ordering Information .....	10-2
Using the Replaceable Parts List .....	10-4

# List of Figures

<b>Figure 2–1: Front view of the benchtop controller .....</b>	<b>2–2</b>
<b>Figure 2–2: Typical system window .....</b>	<b>2–7</b>
<b>Figure 6–1: Removal and installation of the ejectors .....</b>	<b>6–9</b>
<b>Figure 6–2: Removal and installation of the left side cover and rear panel .....</b>	<b>6–10</b>
<b>Figure 6–3: Seating the cover on the chassis .....</b>	<b>6–11</b>
<b>Figure 6–4: Removal and installation of the front panel hardware ..</b>	<b>6–13</b>
<b>Figure 6–5: Subassembly to chassis housing view .....</b>	<b>6–14</b>
<b>Figure 6–6: Removal and installation of the memory SIMMs .....</b>	<b>6–16</b>
<b>Figure 6–7: Controller board and adapter board interconnection ..</b>	<b>6–18</b>
<b>Figure 6–8: Removal and installation of the disk drives .....</b>	<b>6–19</b>
<b>Figure 6–9: Primary troubleshooting tree .....</b>	<b>6–31</b>
<b>Figure 6–10: ResMan32 program output .....</b>	<b>6–34</b>
<b>Figure 6–11: Controller board and adapter board interconnection ..</b>	<b>6–38</b>
<b>Figure 9–1: Controller board block diagram .....</b>	<b>9–1</b>
<b>Figure 9–2: Adapter board block diagram .....</b>	<b>9–2</b>
<b>Figure 10–1: Benchtop controller exploded view .....</b>	<b>10–9</b>



## List of Tables

<b>Table 1–1: Benchtop controller characteristics</b> .....	<b>1–2</b>
<b>Table 1–2: Benchtop controller mechanical characteristics</b> .....	<b>1–3</b>
<b>Table 1–3: Benchtop mainframes external signal interface characteristics</b> .....	<b>1–3</b>
<b>Table 1–4: Benchtop mainframes backplane interface characteristics</b> .....	<b>1–5</b>
<b>Table 1–5: Electromagnetic compatibility (EMC) characteristics</b> ...	<b>1–8</b>
<b>Table 1–6: Atmospheric characteristics</b> .....	<b>1–8</b>
<b>Table 1–7: Dynamic characteristics</b> .....	<b>1–9</b>
<b>Table 1–8: Certifications and compliances</b> .....	<b>1–11</b>
<b>Table 2–1: SVGA OUT connector pin assignments</b> .....	<b>2–4</b>
<b>Table 2–2: COM connector pin assignments</b> .....	<b>2–4</b>
<b>Table 2–3: LPT connector pin assignments</b> .....	<b>2–5</b>
<b>Table 6–1: External inspection check list</b> .....	<b>6–3</b>
<b>Table 6–2: Internal inspection check list</b> .....	<b>6–4</b>
<b>Table 6–3: Tools required for module replacement</b> .....	<b>6–8</b>
<b>Table 6–4: Signal wire identification</b> .....	<b>6–17</b>
<b>Table 6–5: Required documentation</b> .....	<b>6–24</b>
<b>Table 6–6: Failure symptoms and possible causes</b> .....	<b>6–25</b>
<b>Table 6–7: TLA 700 Power-on diagnostic tests</b> .....	<b>6–28</b>
<b>Table 6–8: Command line options for ResMan32</b> .....	<b>6–33</b>
<b>Table 6–9: BIOS error codes and explanations</b> .....	<b>6–35</b>
<b>Table 6–10: Requirements after replacement</b> .....	<b>6–41</b>
<b>Table 7–1: Options</b> .....	<b>7–1</b>
<b>Table 10–1: Standard accessories</b> .....	<b>10–1</b>
<b>Table 10–2: Optional Accessories</b> .....	<b>10–2</b>
<b>Table 10–4: Parts lists column descriptions</b> .....	<b>10–4</b>

# Preface

This is the service manual for the TLA 711 Color Benchtop Controller. Read this preface to learn how this manual is structured, what conventions it uses, and where you can find other information related servicing this product. Read the *Introduction*, which follows this preface, for safety and other important background information needed before using this manual for servicing this product.

## Manual Structure

The *TLA 711 Color Benchtop Controller Service Manual* is divided into chapters, which are made up of related subordinate topics. These topics can be cross referenced as sections.

Be sure to read the introductions to all procedures. These introductions provide important information needed to do the service correctly, safely, and efficiently.

A brief description of each chapter follows:

- *Specifications* contains a product description of the benchtop controller and tables of the characteristics and descriptions that apply to it.
- *Operating Information* includes basic installation and operating instructions at the level needed to safely operate and service the benchtop controller. For complete installation and configuration procedures, refer to the *Installation Manual*. Instructions for shipping the module are also found in this chapter.
- *Theory of Operation* contains circuit descriptions that support general service to the circuit board level.
- *Performance Verification* refers you to the *TLA 700 Series Performance Verification and Adjustment Technical Reference Manual* that contains the performance verification procedures for the benchtop controller and for other major components in the TLA 700 Series Logic Analyzer.
- *Adjustment Procedures* refer you to the *TLA 700 Series Performance Verification and Adjustment Technical Reference Manual* that contains the adjustment procedures for the benchtop controller and for other major components in the TLA 700 Series Logic Analyzer.
- *Maintenance* contains information and procedures for doing preventive and corrective maintenance on the benchtop controller. Included are instructions for cleaning, for removal and installation of replaceable parts, and for troubleshooting.

- *Options* contains information the factory-installed options that may be available for the benchtop controller.
- *Diagrams* contains a block diagram and an interconnection diagram useful for isolating failed circuit boards or assemblies.
- *Mechanical Parts List* includes a table of all replaceable parts, their descriptions, and their Tektronix part numbers.

## Manual Conventions

This manual uses certain conventions that you should become familiar with before attempting service.

### Modules

Throughout this manual, the term *module* refers to a TLA 700 Series Logic Analyzer, DSO, or Benchtop Controller that mounts inside a TLA 700 Series Color Benchtop Chassis. A module is composed of circuit cards, replaceable parts, interconnecting cables, and a user-accessible front panel.

**Benchtop Controller.** In this manual the term “benchtop controller” refers to the TLA 711 Color Benchtop Controller module.

**Benchtop Chassis.** In this manual the term “benchtop chassis” refers to the TLA 711 Color Benchtop Chassis that the TLA 711 Color Benchtop Controller module plugs into.

**Benchtop Mainframe.** In this manual the term “benchtop mainframe” refers to the combination of the TLA 711 Color Benchtop Controller and the TLA 711 Color Benchtop Chassis. When the benchtop controller is mounted in the benchtop chassis the resultant piece of equipment is referred to as the benchtop mainframe.

### Replaceable Parts

This manual refers to any field-replaceable assembly or mechanical part specifically by its name or generically as a replaceable part. In general, a (field) replaceable part is any assembly, such as the hard disk drive, or a mechanical part, such as the I/O port connectors, that is listed in the replaceable parts list of Chapter 10. Also, see *Strategy for Servicing* on page xiii.

### Safety

Symbols and terms related to safety appear in the *General Safety Summary* found at the beginning of this manual.

## Related Manuals

The following manuals are available as part of the TLA 700 Series Logic Analyzer documentation set. (Refer to the part list starting on page 10–6 for manual part numbers.)

The procedures and information in this manual assumes that service personnel have access to all manuals listed in the following table, except for the TLA 7QS (Quick Start) manuals.

Manual Name	Description	Service Use
<i>The TLA 700 Series Installation Manual</i>	Provides the basic installation instructions for the TLA 700 Series Logic Analyzer.	Installation and removal of DSO, Logic Analyzer, and Benchtop-Controller modules  Reinstallation of Windows95 and the TLA 700 software and firmware  Replacing individual podlet cables in the logic analyzer probes  Reformatting the hard disk drive
<i>The TLA 700 Series Performance Verification and Adjustment Technical Reference Manual</i>	Provides performance verification, certification, and adjustment procedures for the TLA 700 Series Logic Analyzer.	Performing periodic or after-repair functional or performance verifications, calibrations/certifications  Performing periodic or after-repair adjustment
<i>The TLA 700 Series User Manual and TLA 700 Online Help</i>	Provides operating information on the TLA 700 Series Logic Analyzer.	Augments operating information found in chapter 2 of this manual.
<i>The TLA 711 Color Benchtop Chassis Service Manual</i>	Provides service information for the color benchtop chassis.	Eliminating the color benchtop chassis as a fault source when trouble shooting the benchtop controller.
<i>The TLA 7Lx/TLA 7Mx Logic Analyzer Service Manual</i>	Provides service information for the logic analyzer modules.	Eliminating the logic analyzer module as a fault source when trouble shooting the benchtop controller.
<i>The TLA 7Dx/TLA 7Ex Digitizing Oscilloscope Service Manual</i>	Provides service information for the digitizing oscilloscope modules.	Eliminating the DSO module as a fault source when trouble shooting the benchtop controller.
<i>The TLA 7QS Training Manual</i>	Provides examples of using the TLA QuickStart training board with TLA 700 Series Logic Analyzers.	None
<i>The TLA 7QS Technical Reference Manual</i>	Provides service information and technical information for the TLA QuickStart Training board.	Servicing the TLA Quickstart Training board only.

## Contacting Tektronix

Product Support	<p>For application-oriented questions about a Tektronix measurement product, call toll free in North America: 1-800-TEK-WIDE (1-800-835-9433 ext. 2400) 6:00 a.m. – 5:00 p.m. Pacific time</p> <p>Or, contact us by e-mail: tm_app_supp@tek.com</p> <p>For product support outside of North America, contact your local Tektronix distributor or sales office.</p>
Service Support	<p>Contact your local Tektronix distributor or sales office. Or, visit our web site for a listing of worldwide service locations.</p> <p><a href="http://www.tek.com">http://www.tek.com</a></p>
For other information	<p>In North America: 1-800-TEK-WIDE (1-800-835-9433) An operator will direct your call.</p>
To write us	<p>Tektronix, Inc. P.O. Box 1000 Wilsonville, OR 97070-1000</p>

# General Safety Summary

Review the following safety precautions to avoid injury and prevent damage to this product or any products connected to it. To avoid potential hazards, use this product only as specified.

*Only qualified personnel should perform service procedures.*

While using this product, you may need to access other parts of the system. Read the *General Safety Summary* in other system manuals for warnings and cautions related to operating the system.

## To Avoid Fire or Personal Injury

**Connect and Disconnect Properly.** Do not connect or disconnect probes or test leads while they are connected to a voltage source.

**Ground the Product.** This product is indirectly grounded through the grounding conductor of the mainframe power cord. To avoid electric shock, the grounding conductor must be connected to earth ground. Before making connections to the input or output terminals of the product, ensure that the product is properly grounded.

**Observe All Terminal Ratings.** To avoid fire or shock hazard, observe all ratings and marking on the product. Consult the product manual for further ratings information before making connections to the product.

Do not apply a potential to any terminal, including the common terminal, that exceeds the maximum rating of that terminal.

**Do Not Operate Without Covers.** Do not operate this product with covers or panels removed.

**Use Proper Fuse.** Use only the fuse type and rating specified for this product.

**Avoid Exposed Circuitry.** Do not touch exposed connections and components when power is present.

**Do Not Operate With Suspected Failures.** If you suspect there is damage to this product, have it inspected by qualified service personnel.

**Do Not Operate in Wet/Damp Conditions.**

**Do Not Operate in an Explosive Atmosphere.**

**Keep Product Surfaces Clean and Dry.**

**Provide Proper Ventilation.** Refer to the manual's installation instructions for details on installing the product so it has proper ventilation.

**Symbols and Terms**

**Terms in this Manual.** These terms may appear in this manual:



---

**WARNING.** Warning statements identify conditions or practices that could result in injury or loss of life.

---



---

**CAUTION.** Caution statements identify conditions or practices that could result in damage to this product or other property.

---

**Terms on the Product.** These terms may appear on the product:

**DANGER** indicates an injury hazard immediately accessible as you read the marking.

**WARNING** indicates an injury hazard not immediately accessible as you read the marking.

**CAUTION** indicates a hazard to property including the product.

**Symbols on the Product.** The following symbols may appear on the product:



WARNING  
High Voltage



Protective Ground  
(Earth) Terminal



CAUTION  
Refer to Manual



Double  
Insulated

# Service Safety Summary

Only qualified personnel should perform service procedures. Read this *Service Safety Summary* and the *General Safety Summary* before performing any service procedures.

**Do Not Service Alone.** Do not perform internal service or adjustments of this product unless another person capable of rendering first aid and resuscitation is present.

**Disconnect Power.** To avoid electric shock, disconnect the main power by means of the power cord or, if provided, the power switch.

**Use Care When Servicing With Power On.** Dangerous voltages or currents may exist in this product. Disconnect power, remove battery (if applicable), and disconnect test leads before removing protective panels, soldering, or replacing components.

To avoid electric shock, do not touch exposed connections.





# Introduction

This manual contains information needed to properly service the benchtop controller. This introduction contains information critical to safe and effective servicing of the benchtop controller.

To prevent personal injury or damage to the benchtop controller, consider the following **requirements** before attempting service:

- The procedures in this manual should be performed only by a qualified service person.
- Read the *General Safety Summary* and *Service Safety Summary* found at the beginning of this manual.
- Read the *Preface* beginning on page v.
- Read *Operating Information* beginning on page 2–1.

When using this manual for servicing, be sure to follow all warnings, cautions, and notes.

## Adjustment Interval

There are no adjustments that can be performed on the benchtop controller.

## Strategy for Servicing

This manual supports and contains all the information needed for periodic maintenance of the benchtop controller.

This manual also supports and contains information for corrective maintenance of this product:

- Supports isolation of faults to the failed circuit board or assembly level shown in the replaceable parts list of Chapter 10
- Supports removal and replacement of those boards or assemblies
- Supports removal and replacement of fuse, knobs, chassis, and other mechanical parts listed in the replaceable parts list

This manual does **not** support component-level fault isolation and replacement.

## Service Offerings

Tektronix provides service to cover repair under warranty as well as other services that are designed to meet your specific service needs.

Whether providing warranty repair service or any of the other services listed below, Tektronix service technicians are well equipped to service the TLA 711 Color Benchtop Controller. Tektronix technicians train on Tektronix products; they have access to the latest information on improvements to the TLA 711 Color Benchtop Controller as well as the latest new product upgrades. *Services are provided at Tektronix Services Centers and on-site at your facility, depending on your location.*

### Warranty Repair Service

Tektronix warrants this product for one year from date of purchase. Tektronix technicians provide warranty service at most Tektronix service locations worldwide. The Tektronix product catalog lists all service locations worldwide.

### Repair or Calibration Service

The following services can be purchased to tailor repair and/or calibration of the benchtop controller to fit your requirements.

**At-Depot Service.** Tektronix offers several standard-priced adjustment (calibration) and repair services:

- A single repair and/or adjustment
- Calibrations using equipment and procedures that meet the traceability standards specific to the local area
- Annual maintenance agreements that provide for repair of the benchtop controller.

Of these services, the annual maintenance agreement offers a particularly cost-effective approach to service for many owners of the benchtop controller.

### Self Service

Tektronix supports repair to the replaceable-part level by providing module exchange.

**For More Information.** Contact your local Tektronix service center or sales engineer for more information on any of the repair or adjustment services just described.



# Specifications

This chapter provides a brief product description, specifications and characteristics of the TLA 711 Color Benchtop Controller.

## Product Description

The benchtop controller is a high-performance personal computer based controller, including graphics and I/O support, that installs in the benchtop chassis. The primary difference between the benchtop controller and a standard personal computer is the communications bus interface used to communicate with the instrument modules located in the benchtop chassis.

Some of the key features are:

- Microsoft Windows 95 operating system
- Standard PC I/O ports, two PCMCIA PC card slots, and a PC-based processor architecture provides automatic connectivity to numerous off-the-shelf I/O devices (modem, printers, etc.)
- An external SVGA port capable of driving large, high-resolution external monitors
- Easy user configurability
- Precision clock, VXIbus trigger line, and event signaling between the benchtop controller and instrument modules supports real-time triggering, sequencing, and time correlation of events
- The benchtop controller is compatible with international power standards, meets international safety and EMC requirements, and tested to rugged environmental standards

## Characteristics Tables

This section contains the specifications and characteristics for the benchtop controller. All specifications and characteristics are warranted unless noted “typical”. Typical characteristics describe typical or average performance and provide useful reference information. Specifications marked with the ✓ symbol

are checked in the *TLA 700 Series Performance Verification and Adjustment Procedures Technical Reference* manual.

Table 1–1 lists the benchtop controller characteristics.

**Table 1–1: Benchtop controller characteristics**

Characteristic	Description																					
Processor	Intel Pentium 133 MHz PC-AT configuration with an Intel 82430HX (Triton II) chip-set																					
Main Memory	EDO DRAM																					
Style	2-72 pin SIMMs, gold plated																					
Loading	Symmetrical, 2-SIMM minimum (64-Bits)																					
Speed	60 ns																					
Installed Configuration	MIN configuration: 16 MByte MAX configuration: 32 MByte																					
Cache Memory	256 Kbyte, level 2 (L2) write-back cache																					
Flash BIOS	512 Kbyte																					
Real-Time Clock and CMOS Setups NVRAM (Typical)	Real-Time clock/calendar, with typical 10-year life. Standard and advanced PC CMOS setups: see BIOS specification. Year 2000 compliant.																					
Floppy Disk Drive	Standard 3.5 inch, 1.44 Mbyte, double-sided, PC-compatible high-density floppy disk drive																					
Hard Disk Drive	Standard PC-compatible with ATA/Enhanced Integrated Device Electronics (EIDE) interface																					
Formatted Capability	MIN configuration: 840 MByte MAX configuration: 2.16 GByte Subject to change; these are the storage capacities valid at product introduction																					
Display Classification	Standard PC graphics accelerator technology (bitBLT based) capable of driving external color VGA, SVGA, or XGA monitors																					
Display Memory	DRAM based frame-buffer memory																					
Width	32 Bit																					
Size	1 MByte																					
Display Drive	One VGA, SVGA, or XGA compatible analog output port																					
Display Size	User selected via Windows 95																					
	<table border="0"> <thead> <tr> <th>Resolution (Pixels)</th> <th>Colors</th> <th>DDC1</th> </tr> </thead> <tbody> <tr> <td>640x480</td> <td>256</td> <td>yes</td> </tr> <tr> <td>640x480</td> <td>64K</td> <td>yes</td> </tr> <tr> <td>640x480</td> <td>16.8M</td> <td>no</td> </tr> <tr> <td>800x600</td> <td>256</td> <td>yes</td> </tr> <tr> <td>800x600</td> <td>64K</td> <td>yes</td> </tr> <tr> <td>1024x768</td> <td>256</td> <td>yes</td> </tr> </tbody> </table>	Resolution (Pixels)	Colors	DDC1	640x480	256	yes	640x480	64K	yes	640x480	16.8M	no	800x600	256	yes	800x600	64K	yes	1024x768	256	yes
Resolution (Pixels)	Colors	DDC1																				
640x480	256	yes																				
640x480	64K	yes																				
640x480	16.8M	no																				
800x600	256	yes																				
800x600	64K	yes																				
1024x768	256	yes																				
Mouse Port	Front panel mounted PS2 compatible mouse port utilizing a mini-DIN connector																					

**Table 1–1: Benchtop controller characteristics (cont.)**

Characteristic	Description
Keyboard Port	Front panel mounted PS2 compatible keyboard port utilizing a mini-DIN connector
Parallel Interface Port (LPT)	Parallel interface port supports standard Centronics mode, Enhanced Parallel Port (EPP), or Microsoft high-speed mode (ECP) and utilizes a 36-pin high-density connector
Serial Interface Port (COM)	The serial port utilizing a 9-pin male sub-D connector to support an RS232 serial port. Compliant with EIA/TIA 574
SVGA Output Port (SVGA)	The SVGA port utilizing a 15-pin sub-D SVGA connector. Compliant with EIA RS 343A
Type I and II PC Card Port	Standard Type I and II PC compatible PC card slot. Compliant with PCMCIA and JEDIA 4.1
Type I, II, and III PC Card Port	Standard Type I, II, and III PC compatible PC card slot. Compliant with PCMCIA and JEDIA 4.1

Table 1–2 lists the benchtop controller mechanical characteristics.

**Table 1–2: Benchtop controller mechanical characteristics**

Characteristic	Description
Weight	5 lb. 3 oz. (2.34 kg)
Size	Standard dual-wide, VXI C-size enclosure
Overall dimensions	
Height	10.32 in (262 mm)
Width	2.39 in (61 mm)
Depth	14.7 in (373 mm)

Table 1–3 lists the external signal interface characteristics for the benchtop mainframe.

**Table 1–3: Benchtop mainframes external signal interface characteristics**

Characteristic	Description
System Trigger Input	TTL compatible input via rear panel mounted BNC connectors (portable mainframe) or front panel mounted SMB connectors (benchtop mainframe)
Input Levels	TTL compatible input.
$V_{IH}$	$\geq 2.0\text{ V}$
$V_{IL}$	$\leq 0.8\text{ V}$
Input Mode	Falling edge sensitive, latched (active low)

Table 1–3: Benchtop mainframes external signal interface characteristics (cont.)

Characteristic	Description
Minimum Pulse Width	12 ns
Active Period	Accepts system triggers during valid acquisition periods via real-time gating, resets system trigger input latch between valid acquisition periods
Maximum Input Voltage	0 to +5 Volt peak
External Signal Input	TTL compatible input via rear panel mounted BNC connectors (portable mainframe) or front panel mounted SMB connectors (benchtop mainframe)
Input Destination	Signal 1, 2, 3, 4
Input Levels $V_{IH}$ $V_{IL}$	TTL compatible input. $\geq 2.0\text{ V}$ $\leq 0.8\text{ V}$
Input Mode	Active (true) low, level sensitive
Input Bandwidth Signal 1, 2 Signal 3, 4	50 MHz square wave minimum <sup>1</sup> 10 MHz square wave minimum <sup>1</sup>
Active Period	Accepts signals during valid acquisition periods via real-time gating
Maximum Input Voltage	0 to +5 Volt peak
System Trigger Output	TTL compatible output via rear panel mounted BNC connectors (portable mainframe) or front panel mounted SMB connectors (benchtop mainframe)
Source Mode	Active (true) low, falling edge latched
Active Period	Outputs system trigger state during valid acquisition period, resets system trigger output to false state between valid acquisitions
Output Levels $V_{OH}$	50 Ohm back terminated TTL-compatible output $\geq 4\text{ V}$ into open circuit $\geq 2\text{ V}$ into 50 Ohm to ground
$V_{OL}$	$\geq 0.7\text{ V}$ sinking 10 ma
Output Protection	Short-circuit protected (to ground)
Intermodule Signal Line Bandwidth	Minimum bandwidth up to which the intermodule signals are specified to operate correctly Signal 1, 2 (ECLTRG0, 1) 50 MHz square wave minimum Signal 3, 4 (TTLTRG0, 1) 10 MHz square wave minimum
External Signal Output	TTL compatible outputs via rear panel mounted BNC connectors (portable mainframe) or front panel mounted SMB connectors (benchtop mainframe)
Source Selection	Signal 1, 2, 3, 4, or 10 MHz clock
Output Modes Level Sensitive	User definable Active (true) low or active (true) high
Output Levels $V_{OH}$	50 Ohm back terminated TTL output $\geq 4\text{ V}$ into open circuit $\geq 2\text{ V}$ into 50 Ohm to ground
$V_{OL}$	$\leq 0.7\text{ V}$ sinking 10 ma



Table 1–3: Benchtop mainframes external signal interface characteristics (cont.)

Characteristic	Description
Output Bandwidth Signal 1, 2 Signal 3, 4	50 MHz square wave minimum <sup>2</sup> 10 MHz square wave minimum <sup>2</sup>
Active Period	Outputs signals during valid acquisition periods, resets signals to false state between valid acquisitions  Outputs 10 MHz clock continuously
Output Protection	Short-circuit protected (to ground)

<sup>1</sup> The Input Bandwidth only applies to signals to the modules, not round trip signals into the External Signal Input and back out the External Signal Outputs.

<sup>2</sup> The Output Bandwidth only applies to signals to the modules, not round trip signals into the External Signal Input and back out the External Signal Outputs.

Table 1–4 lists the backplane interface characteristics for the benchtop mainframe.

Table 1–4: Benchtop mainframes backplane interface characteristics

Characteristic	Description
Slots	
Benchtop mainframe	13
✓ CLK10 Frequency	10 MHz ±100 PPM
Relative Time Correlation Error <sup>1,2</sup> (Typical)	
LA to LA “MagniVu” data	2 ns
LA to LA “normal” data utilizing an internal clock <sup>9</sup>	1 LA Sample – 0.5 ns
LA to LA “normal” data utilizing an external clock	2 ns
LA “MagniVu” to DSO data	3 ns
LA to DSO “normal” data utilizing an internal clock <sup>8,9</sup>	1 LA Sample + 1 ns
LA to DSO “normal” data utilizing an external clock <sup>8</sup>	3 ns
DSO to DSO (channel 1 to channel 1 only)	3 ns
System Trigger and External Signal Input Latencies <sup>3,7</sup> (Typical)	
External System Trigger Input to LA Probe Tip <sup>4</sup>	–27/ns
External Signal Input to LA Probe Tip via Signal 3, 4 <sup>5</sup>	–212 ns + Clk
External Signal Input to LA Probe Tip via Signal 1, 2 <sup>5,6</sup>	–208 ns + Clk

**Table 1–4: Benchtop mainframes backplane interface characteristics (cont.)**

Characteristic	Description
External System Trigger Input to DSO Probe Tip <sup>4</sup>	–27 ns
System Trigger and External Signal Output Latencies <sup>3</sup> ( <i>Typical</i> )	
LA Probe Tip to External System Trigger Out <sup>9</sup>	380 ns + Smpl
LA Probe Tip to External Signal Out via Signal 3, 4 <sup>9</sup>	
OR function	371 ns + Smpl
AND function	383 ns + Smpl
LA Probe Tip to External Signal Out via Signal 1, 2 <sup>6, 9</sup>	
normal function	381 ns + Smpl
inverted logic on backplane	384 ns + Smpl
DSO Probe Tip to External System Trigger Out	70 ns
DSO Probe Tip to External Signal Out via Signal 3, 4	
OR function	68 ns
AND function	78 ns
DSO Probe Tip to External Signal Out via Signal 1, 2 <sup>6</sup>	
normal function	71 ns
inverted logic on backplane	71 ns
Inter-Module Latencies <sup>3</sup> ( <i>Typical</i> )	
LA to DSO Inter-module System Trigger <sup>4, 9</sup>	358 ns + Smpl
LA to LA Inter-module System Trigger <sup>4, 9</sup>	68 ns + Smpl
LA to DSO Inter-Module ARM <sup>9</sup>	360 ns + Smpl
LA to LA Inter-Module ARM <sup>5, 9</sup>	108 ns + Clk
LA to LA Inter-Module via Signal 1, 2 <sup>5, 6, 9</sup>	120 ns + Clk
LA to LA Inter-Module via Signal 3, 4 <sup>5, 9</sup>	116 ns + Clk
DSO to DSO Inter-module System Trigger <sup>4</sup>	50 ns
DSO to LA Inter-module System Trigger <sup>4</sup>	–236 ns
DSO to LA Inter-Module ARM <sup>5</sup>	–192 ns + Clk
DSO to DSO Inter-Module ARM	59 ns

Table 1–4: Benchtop mainframes backplane interface characteristics (cont.)

Characteristic	Description
DSO to LA Inter-Module via Signal 1, 2 <sup>5, 6</sup>	-179 ns + Clk
DSO to LA Inter-Module via Signal 3, 4 <sup>5</sup>	-184 ns + Clk

- <sup>1</sup> Includes typical jitter, slot-to-slot skew, and probe-to-probe variations to provide a “typical” number for the measurement. Assumes standard accessory probes are utilized.
- <sup>2</sup> For time intervals longer than 1  $\mu$ s between modules, add 0.01% of the difference between the absolute time measurements to the relative time correlation error to account for the inaccuracy of the CLK10 source.
- <sup>3</sup> Latencies are based on typical portable mainframe configurations consisting of two LA modules or an LA module plus a DSO module. Latencies are system-configuration-dependent and may vary slightly with module loading.
- <sup>4</sup> In the Waveform window, triggers are always marked immediately except when delayed to the first sample. In the Listing window, triggers are always marked on the next sample period following their occurrence.
- <sup>5</sup> “Clk” represents the time to the next “master” clock at the destination logic analyzer. In the asynchronous (or internal) clock mode, this represents the delta time to the next sample clock beyond the minimum async rate of 4 ns. In the synchronous (or external) clock mode, this represents the time to the next master clock generated by the setup of the clocking state machine and the supplied SUT clocks and qualification data.
- <sup>6</sup> Signals 1 and 2 (ECLTRG0, 1) are limited to a “broadcast” mode of operation, where only one source is allowed to drive the signal node at any one time. That single source may be utilized to drive any combination of destinations.
- <sup>7</sup> All system trigger and external signal input latencies were measured from a falling edge transition (active/true low) with signals measured in the “wired-OR” configuration.
- <sup>8</sup> DSO module time correlation was measured at maximum sample rate on channel one only.
- <sup>9</sup> The term “Smpl” represents the time from the event at the probe tip inputs, to the next valid data sample of the LA. In the “normal” “internal” clock mode this represents the data to the next sample clock. In “MagniVu” internal clock mode this represents 500 ps or less. In the “external” clock mode this represents the time to the next master Clk generated by the setup of the clocking state machine and the supplied SUT clocks and qualification data.

Table 1–5 lists the electromagnetic compatibility (EMC) characteristics.

**Table 1–5: Electromagnetic compatibility (EMC) characteristics**

Characteristic	Description												
Emissions	Emissions shall be within the limits specified by the following requirements:												
Enclosure	EN 55011 Class A limits for radiated emissions												
Immunity, Enclosure, Radio Frequency Electromagnetic Field	No instrument failures when the instrument is subjected to a 3 V/m electromagnetic field over the frequency range of 27 MHz to 500 MHz												
Immunity, Enclosure, Electrostatic Discharge (ESD)	Up to 8 kV with no change to control settings or impairment of normal operation												
Immunity, Fast transients, Electrical	No loss of stored data, change to control settings, degradation of performance, or temporary loss of function will occur when the system is subjected to the transients as described below												
	<table border="1"> <thead> <tr> <th>Port</th> <th>Peak Voltage</th> <th>Tr/Th</th> <th>Rep Frequency</th> </tr> </thead> <tbody> <tr> <td>Signal &amp; Control</td> <td>0.5 kV</td> <td>5/50 ns</td> <td>5 kHz</td> </tr> <tr> <td>AC Power</td> <td>1.0 kV</td> <td>5/50 ns</td> <td>5 kHz</td> </tr> </tbody> </table>	Port	Peak Voltage	Tr/Th	Rep Frequency	Signal & Control	0.5 kV	5/50 ns	5 kHz	AC Power	1.0 kV	5/50 ns	5 kHz
Port	Peak Voltage	Tr/Th	Rep Frequency										
Signal & Control	0.5 kV	5/50 ns	5 kHz										
AC Power	1.0 kV	5/50 ns	5 kHz										

Table 1–6 lists the atmospheric characteristics.

**Table 1–6: Atmospheric characteristics**

Characteristic	Description
Temperature: Operating and non-operating	<p>Operating (no media in floppy disk drive) +5° C to +50° C, 15° C/hour maximum gradient, non-condensing (derated 1° C per 1000 feet above 5000 foot altitude)</p> <p>Non-operating (no media in floppy disk drive) –20° C to +60° C, 15° C/hour maximum gradient, non-condensing</p>
Humidity: Operating and non-operating	<p>Operating (no media in floppy disk drive) 20% to 80% relative humidity, non-condensing. Maximum wet bulb temperature: +29° C (derated relative humidity to approximately 22% at +50° C)</p> <p>Non-operating (no media in floppy disk drive) 8% to 80% relative humidity, non-condensing. Maximum wet bulb temperature: +40° C (derated relative humidity to approximately 55% at +50° C)</p>
Altitude: Operating and non-operating	<p>Operating: To 10,000 feet (3040 meters), (derated 1° C per 1000 feet (305 meters) above 5000 feet (1524 meters) altitude)</p> <p>Non-operating: 40,000 feet (12190 meters)</p>

Table 1–7 lists the dynamic characteristics.

**Table 1–7: Dynamic characteristics**

Characteristic	Description
Random Vibration: Operating and non-operating	<p>Operating: 0.27 g<sub>rms</sub> total from 5 Hz to 500 Hz, 10 minutes each axis, 3-axes, 30 minutes total</p> <p>Profile: 0.00015 g<sup>2</sup>/Hz 5-350 Hz, -0.3dB/octave slope 100-200 Hz, 0.000105 g<sup>2</sup>/Hz</p> <p>Non-operating: 2.28 g<sub>rms</sub> total from 5 Hz to 500 Hz, 10 minutes each axis, 3-axes, 30 minutes total</p> <p>Profile: 0.0175 g<sup>2</sup>/Hz 5-100Hz, -0.3dB/octave slope 100-200 Hz, 0.00875g<sup>2</sup>/Hz 200-350 Hz, -0.3dB/octave slope 350-500 Hz, 0.006132 g<sup>2</sup>/Hz</p>



# Certifications and Compliances

**Table 1-8: Certifications and compliances**

EC Declaration of Conformity – EMC	Meets intent of Directive 89/336/EEC for Electromagnetic Compatibility. Compliance was demonstrated to the following specifications as listed in the Official Journal of the European Communities: EN 55011                      Class A Radiated and Conducted Emissions  EN 50081-1 Emissions: EN 60555-2              AC Power Line Harmonic Emissions  EN 50082-1 Immunity: IEC 801-2              Electrostatic Discharge Immunity IEC 801-3              RF Electromagnetic Field Immunity IEC 801-4              Electrical Fast Transient/Burst Immunity IEC 801-5              Power Line Surge Immunity
------------------------------------	---







# Operating Information

This chapter contains information about operating the benchtop controller. Refer to the *TLA 700 Series Installation Manual* for complete information on how to install and configure the benchtop controller.

## Installation

The benchtop controller is a control module that is an integral part of the benchtop chassis. To install the benchtop controller into the benchtop chassis refer to the installation manual.

The installation guide also covers installation of Windows 95, TLA 700 software, as well as the reformatting of the hard disk drive.

## Hardware Interface

The benchtop controller hardware interface is a C-size, VXIbus system interface. The benchtop controller is a slot zero device that occupies two slots, and therefore must be installed in slot zero and one of the benchtop chassis.

The benchtop controller uses a PCI-to-VXI interface for communication between the benchtop controller and the benchtop chassis.

**LED Indicators**

The benchtop controller has three LED indicators located on the front panel. Figure 2-1 shows the front panel with the location of the LED indicators and front panel connectors.

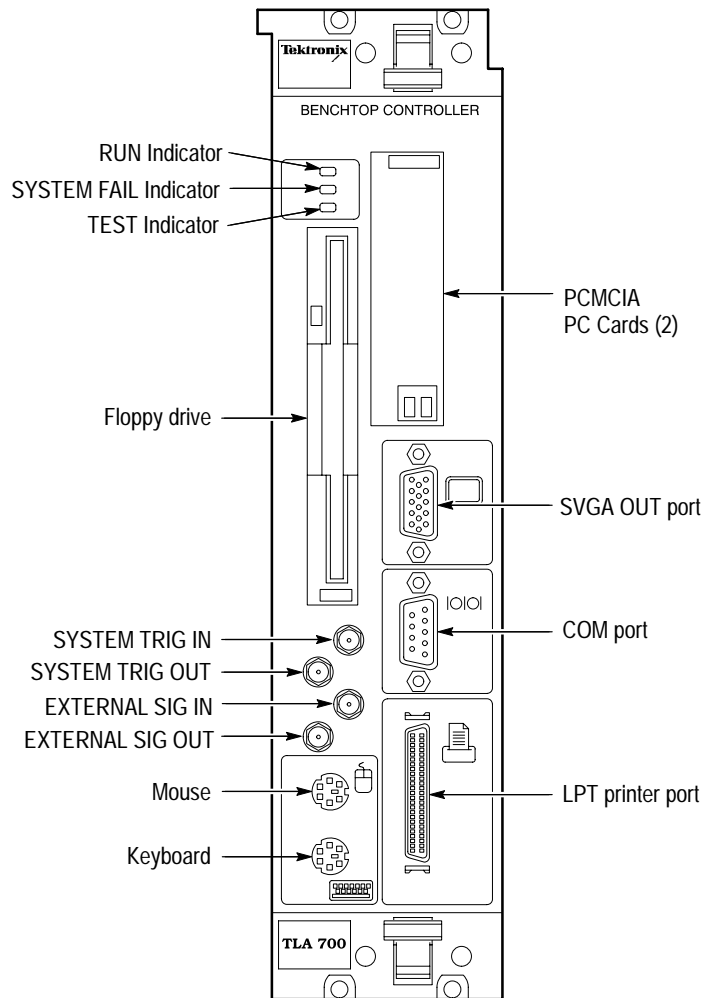

**Figure 2-1: Front view of the benchtop controller**

**RUN Indicator.** A green LED that lights when the hard disk drive is accessing data.

**SYSTEM FAIL Indicator.** A red LED lights when a SYSFAIL condition exists on the communications bus.

**TEST Indicator.** A yellow indicator lights when the benchtop controller is executing a Power On Self Test (POST) diagnostic test sequence.

**Test I/O SMBs**

The benchtop controller has four test I/O Sub-Miniature Bayonet (SMB) connectors: System trigger input, system trigger output, external signal input, and external signal output.

**SYSTEM TRIG IN Connector.** The system trigger input is a TTL compatible signal input that is user definable in software. The system trigger input utilizes an SMB connector. Refer to the *TLA 700 Series User Manual* for additional information.

**SYSTEM TRIG OUT Connector.** The system trigger output is a TTL compatible output signal that is user definable in software. The system trigger output utilizes an SMB connector. Refer to the *TLA 700 Series User Manual* for additional information.

**EXTERNAL SIG IN Connector.** The external signal Input is a TTL compatible input signal that is user definable in software. The external signal Input utilizes an SMB connector. The system trigger input is user definable in software. Refer to the *TLA 700 Series User Manual* for additional information.

**EXTERNAL SIG OUT Connector.** The external signal output is a TTL compatible output signal that is user definable in software. The system trigger output utilizes an SMB connector. Refer to the *TLA 700 Series User Manual* for additional information.

**Mouse and Keyboard Connectors**

The benchtop controller has two PS2 compliant mini-DIN connectors. One connector supports an external mouse and the other connector supports an external keyboard. Descriptions of the two ports follow.

**MOUSE Connector.** The mouse connector is a standard PS2 compliant connector. The mouse port supports the connection of an external, standard mouse, or pointing device.

**KEYBOARD Connector.** The keyboard connector is a standard PS2 compliant connector. The keyboard port supports the connection of an external standard keyboard.

**PCMCIA PC Card Port**

The benchtop controller supports up to two, industry standard Type I and Type II PC Card slots. The slots are compliant with PCMCIA (Personal Computer Memory Card Industry Association) 2.1, and JEIDA 4.1. The PC card(s) can be inserted in either slot, or two cards can occupy both slots at the same time.

The PCMCIA PC card port supports an optional ethernet Network Interface Card (NIC) for network connectivity.

**I/O Ports** The benchtop controller has three I/O Ports: a SVGA OUT port, a COM port, and a LPT port. Descriptions of the three ports follow.

**SVGA OUT Connector.** The SVGA OUT port supports an industry-standard SVGA color monitor. The connector is a 15-pin, sub-D SVGA compliant connector. See Table 2–1 for pin assignments.

**Table 2–1: SVGA OUT connector pin assignments**

Pin number	Pin function	Pin number	Pin function
1	RED	2	GRN
3	BLU	4	DDC DB2
5	GND	6	GND
7	GND	8	GND
9	(KEY)	10	GND
11	DDC DB0	12	DDC DB1
13	HSYNC	14	VSYNC
15	DDC DB3		

**COM Connector.** The COM port is an RS-232 serial port. The connector is a 9-pin male, sub-D plug (male pins). The COM port is compliant to EIA/TIA 574. See Table 2–2 for pin assignments.

**Table 2–2: COM connector pin assignments**

Pin number	Pin function	Pin number	Pin function
1	DCD	2	RXD
3	TXD	4	DTR
5	GND	6	DSR
7	RTS	8	CTS
9	Ring Indicator		

**LPT Connector.** The LPT port is a parallel printer port. This parallel printer port supports standard Centronics mode, Enhanced Parallel Port (EPP), or Microsoft high-speed mode (ECP), and utilizes a 36-pin high density Centronics compliant connector. The LPT port is compliant with IEEE P1284-C/D2 for bidirectional Parallel Peripheral Interface for Personal Computers style 1284-C. See Table 2–3 for pin assignments.

**Table 2-3: LPT connector pin assignments**

Pin number	Pin function	Pin number	Pin function
1	BUSY	19	GND
2	SLCT	20	GND
3	ACK	21	GND
4	ERR	22	GND
5	PE	23	GND
6	D0	24	GND
7	D1	25	GND
8	D2	26	GND
9	D3	27	GND
10	D4	28	GND
11	D5	29	GND
12	D6	30	GND
13	D7	31	GND
14	INIT	32	GND
15	STB	33	GND
16	SLIN	34	GND
17	AFD	35	GND
18	HI?	36	GND

Note: See IEEE specification P1284-C for pin connection definitions for other modes

### Floppy Disk Drive

The benchtop controller has one standard 1/2 inch drive, that supports 3.5 inch, 1.44 MByte, high-density/double-sided floppy disks.

**Hard Disk Drive** The benchtop controller has one standard 2.5 inch IDE drive which interfaces directly to the controller via an Enhanced Integrated Device Electronics (IDE) extension of the PCI bus. The hard disk drive is available in two configurations: a minimum configuration and a maximum configuration. The configurations offered are subject to frequent change due to the fast-moving personal computer component environment.

**Memory SIMMs** The benchtop controller has allocations for two 72-pin EDO DRAM memory SIMMs. The SIMMs must be loaded symmetricly (in pairs), two SIMM minimum (64-bits). The SIMMs speed requirement is 60 ns minimum.

Memory requirements are 16 MByte minimum configuration, or 32 MByte maximum configuration.

## Operating System and Application Interface

The benchtop controller ships with the Windows 95 operating system factory installed. Operations and capabilities when running on the benchtop controller are the same as with Windows 95 running on a high-performance personal computer. Windows Help is available from the Start menu of the Windows 95 Task Bar. The Windows 95 software is included with the product. See the software and the *TLA 700 Series Installation Manual* if you need to reinstall the Windows 95 application.

The benchtop controller also comes with the TLA Series software application that is configured at the factory to launch after the logic analyzer boots up and Windows 95 is running. The TLA Series application is used to control data acquisition and processing by the logic analyzer. The TLA Series application software is included with the product. Refer to the *TLA 700 Series Installation Manual* if you need to reinstall the TLA Series software application.

The topics that follow provide a brief overview of the TLA Series software application. Refer to the online help and the *TLA 700 Series Logic Analyzer User Manual* for additional information.

**System Window** This window provides an overview of the entire logic analyzer. Use this window to navigate through the logic analyzer. Figure 2–2 shows an example of the system window.

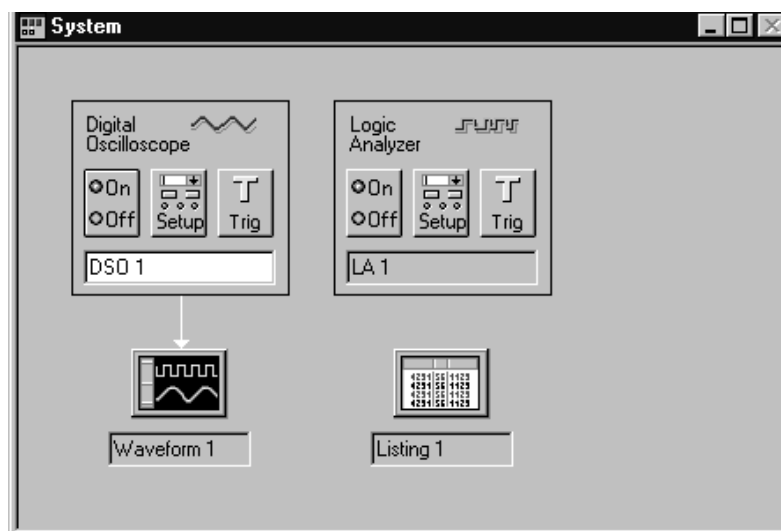

Figure 2–2: Typical system window

The center of the system window displays icons which represent hardware modules installed in the logic analyzer. The images are links to the other windows in the logic analyzer.

**Trigger Window** The trigger windows provides access to the logic analyzer trigger hardware. You can specify the data patterns that you want to acquire and how much data to acquire by defining the trigger setups in menus and dialogs. Refer to the online help and the *TLA 700 Series Logic Analyzer User Manual* for additional information.

**Listing Data Window** The listing data window displays acquired data as tabular text. Each column of data represents one group of data or other logical data information, such as timestamps. Each row of data represents a different time that the data was acquired; newer samples of data display below older samples. Refer to the online help and the *TLA 700 Series Logic Analyzer User Manual* for additional information.

**Waveform Data Window** The waveform data window displays acquired data as graphical waveforms. All defined channel groups display as busforms for the logic analyzer and as individual channels for the digitizing oscilloscope. Refer to the online help and the *TLA 700 Series Logic Analyzer User Manual* for additional information.



**Setup Window** A setup window exists for each module in the logic analyzer. It contains all of the setup information for the benchtop controller such as clocking, memory depth, threshold information, and channel information. Menus and dialogs contain information to set up the window as needed. Most of the changes that you make in the menus or dialogs take effect at the end of the acquisition; however, probe threshold changes take effect immediately. Refer to the online help and the *TLA 700 Series Logic Analyzer User Manual* for additional information.

**Online Help** Most of the user information for operating the benchtop controller is available through the online Windows Help screens. Refer to your Microsoft Windows documentation for additional information on using Windows Help.

Refer to the online help for more information on the individual menus, icons, and fields within each window. You may also want to refer to the *TLA 700 Series Logic Analyzer User Manual* for additional information.

## Diagnostics

The benchtop controller performs power-on BIOS diagnostics every time you power on the mainframe. The diagnostics window displays when any of the diagnostic tests fail. To access the diagnostics tests, use the System pull-down menu.

In addition to power-on diagnostics, there are two other utilities to aid in troubleshooting. The other two utilities are QAPlus/WIN and the TLA 700 Mainframe Diagnostics. Refer to the Maintenance section for information on diagnostics.



# Theory of Operation

This chapter contains a block level description of the benchtop controller. This information supports fault isolation to the module, and replaceable part level. Refer to the *Diagrams* section for a block level diagram of the benchtop controller.

## Block Level Description

The *Block Level Description* describes circuit operation to the functional block level.

The benchtop controller is a high-performance personal computer based controller including graphics and I/O. The primary difference between the benchtop controller and a standard personal computer is the communications bus interface used to communicate with the benchtop chassis and the instrument modules. The benchtop controller consists of two boards, the controller board and the adapter board.

<b>Controller Board</b>	The controller board is a personal computer controller utilizing standard Intel Pentium-AT architecture. The controller board has a PCI to PCMCIA PC card host adapter that is used to control the two PC card slots. The controller has one ECP/EEP Centronics compatible parallel port, and two 16550 based serial RS-232 COM ports (one external) to support standard PC based I/O peripherals.
<b>Adapter Board</b>	The adapter board provides both electrical and mechanical support to the controller board. The adapter board supports the hard and floppy disk drives, keyboard and mouse ports, PC speaker, decoding and buffering to the communications bus.
<b>Hard Disk Drive</b>	The hard disk drive is a standard 2.5 inch IDE drive which interfaces directly to the controller via an Enhanced Integrated Device Electronics (IDE) extension of the PCI bus.
<b>Floppy Disk Drive</b>	The floppy disk drive is a standard 1/2 inch drive that supports 3.5 inch, 1.44 MByte high density/double sided floppy disks.
<b>Mouse and Keyboard Ports</b>	The mouse and keyboard ports are standard PS2 compliant ports interfaced by the adapter board to the controller.







## Performance Verification

Refer to the *TLA 700 Series Logic Analyzer Performance Verification and Adjustment Procedures Technical Reference* for complete performance verification procedures for the TLA 711 Color Benchtop Controller.









# Adjustment Procedures

There are no adjustments on the TLA 711 Color Benchtop Controller.





# Maintenance

This chapter contains information needed to perform periodic corrective maintenance on the benchtop controller. The following sections are included:

- The *Maintenance* section provides general information on preventing damage to internal circuit boards when performing maintenance, and procedures for inspecting and cleaning external and internal parts.
- The *Removal and Installation Procedures* provide procedures for the removal and installation of replaceable parts.
- The *Troubleshooting* section provides information on isolating failed modules. Included are system-level instructions that isolate faults within your system, and troubleshooting trees that supplement the internal self tests to isolate faulty replaceable parts.
- The *Repackaging Instructions* provides packaging information for shipment and storage.

## Related Maintenance Procedures

The following chapters contain information and procedures related to maintenance:

- The *Operating Information* chapter provides information on operating the benchtop controller in order to perform the maintenance procedures in this manual.
- The *Theory of Operation* chapter contains circuit and module descriptions.
- The *Performance Verification* chapter references the *TLA 700 Series Logic Analyzer Performance Verification and Adjustment Procedures Technical Reference*.
- The *Diagrams* chapter contains a block diagram of the benchtop controller.
- The *Replaceable Mechanical Parts* and *Replaceable Electrical Parts* chapters list all of the replaceable parts by part number.

Refer to the *TLA 700 Series Installation Manual* for software maintenance procedures for the benchtop controller.

## Preventing ESD

When performing any service which requires internal access to the benchtop controller, adhere to the following precautions to avoid damaging internal circuit boards and their components due to electrostatic discharge (ESD).



---

**CAUTION.** *Static discharge can damage any semiconductor component in this benchtop controller*

---

1. Minimize handling of static-sensitive circuit boards.
2. Transport and store static-sensitive circuit boards in their static protected containers or on a metal rail. Label any package that contains static-sensitive boards.
3. Discharge the static voltage from your body by wearing a grounded antistatic wrist strap while handling these circuit boards. Perform service of static-sensitive circuit boards only at a static-free work station.
4. Nothing capable of generating or holding a static charge should be allowed on the work station surface.
5. Handle circuit boards by the edges when possible.
6. Do not slide the circuit boards over any surface.
7. Avoid handling circuit boards in areas that have a floor or work-surface covering capable of generating a static charge.



---

**WARNING.** *To avoid electric shock, always power off the chassis and disconnect the power cord before cleaning or servicing the chassis.*

---

## Inspection and Cleaning

The benchtop controller is inspected mechanically and electrically before shipment. It should be free of marks or scratches and should meet or exceed all electrical specifications. To confirm this, inspect for physical damage incurred during transit. Retain the packaging in case shipment for repair is necessary. If there is damage or deficiency, contact your local Tektronix representative.

Cleaning procedures consist of exterior and interior cleaning. Periodic cleaning reduces instrument breakdown and increases reliability. Clean the benchtop controller as needed, based on your operating environment.

### Exterior Inspection

Inspect the outside of the benchtop controller for damage, wear, and missing parts. Use Table 6–1 as a guide. Modules that appear to have been dropped or otherwise abused should be checked thoroughly to verify correct operation and performance. Immediately repair defects that could cause personal injury or lead to further damage to the benchtop controller or the benchtop chassis that the module plugs into.

**Table 6–1: External inspection check list**

Item	Inspect for	Repair action
Front panel and side cover	Cracks, scratches, deformations, missing or damaged retainer screws, or ejector handles.	Replace defective or missing parts.
Front panel connectors	Broken shells, cracked insulation, and deformed contacts. Dirt in connectors.	Replace defective parts. Clear dirt out of connectors.
Rear connectors	Cracked or broken shells, damaged or missing contacts. Dirt in connectors.	Replace defective parts. Clear dirt out of connectors.
Accessories	Missing items or parts of items, bent pins, broken or frayed cables, and damaged connectors.	Replace damaged or missing parts, frayed cables.



**CAUTION.** To prevent damage to electrical components from moisture during external cleaning, use only enough liquid to dampen the cloth or applicator.

### Exterior Cleaning Procedure

Clean the exterior surfaces with a soft dry lint-free cloth, or a soft-bristle brush. If any dirt remains, use a soft cloth or swab dipped in a 75% isopropyl alcohol solution. Use a swab to clean narrow spaces around controls and connectors. Do not use abrasive cleaning compounds on any part of the benchtop controller.



**CAUTION.** Avoid getting moisture inside the benchtop controller during exterior cleaning; use just enough moisture to dampen the cloth or swab.

Use only deionized water when cleaning. Use a 75% isopropyl alcohol solution as a cleanser and rinse with deionized or distilled water.

Do not use chemical cleaning agents; they may damage the chassis. Avoid chemicals that contain benzene, toluene, xylene, acetone, or similar solvents.

### Interior Inspection

Remove the module cover to access the inside of the benchtop controller for inspection and cleaning. Refer to the *Removal and Installation Procedures* section on page 6–7 for detailed information on cover removal. Inspect the internal portions of the benchtop controller for damage and wear using Table 6–2 as a guide. Defects found should be repaired immediately.

**Table 6–2: Internal inspection check list**

Item	Inspect for	Repair action
Circuit boards	Loose, broken, or corroded solder connections. Burned circuit boards. Burned, broken, or cracked circuit-run plating.	Return to a Tektronix Service Center.
Resistors	Burned, cracked, broken, blistered condition.	Return to a Tektronix Service Center.
Solder connections	Cold solder or rosin joints.	Return to a Tektronix Service Center.
Capacitors	Damaged or leaking cases. Corroded solder on leads or terminals.	Return to a Tektronix Service Center.
Semiconductors	Loosely inserted in sockets. Distorted pins.	Firmly seat loose semiconductors. Remove devices that have distorted pins. Carefully straighten pins (as required to fit the socket), and reinsert firmly. Ensure that straightening action does not crack pins, causing them to break off.
Wiring and cables	Loose plugs or connectors. Burned, broken, or frayed wiring.	Firmly seat connectors. Repair or replace parts with defective wires or cables.
Chassis	Dents, deformations, and damaged hardware.	Straighten, repair, or replace defective hardware.



**CAUTION.** To prevent damage from electrical arcing, ensure that circuit boards and components are dry before applying power to the benchtop controller.

**Interior Cleaning  
Procedure**

Use a dry, low-velocity stream of air to clean the interior of the benchtop controller. Use a soft-bristle brush for cleaning around components. If you must use a liquid for minor interior cleaning, use a 75% isopropyl alcohol solution and rinse with deionized or distilled water.

You will need a 3.5 inch floppy disk drive head cleaning kit for routine maintenance of the floppy disk drive. The routine maintenance and cleaning schedules will depend upon usage. A basic monthly routine maintenance is as follows:

- Clean the exterior (face) of the floppy disk drive with a soft clean cloth and a mild detergent.
- Use a commercially available floppy disk drive head cleaner kit, and follow the manufacturers instructions.





# Removal and Installation Procedure

This section contains information needed to perform corrective maintenance on the benchtop controller.

## Preparation – Please Read

Be sure to observe the following precautions to avoid damaging the benchtop controller while preparing to service it.



---

**CAUTION.** *Many components within the benchtop controller and chassis are susceptible to static-discharge damage.*

*Service the benchtop controller only in a static-free environment. Observe standard handling precautions for static-sensitive devices. Always wear a grounded wrist strap, or equivalent, while servicing the benchtop controller*

---

- Do not handle static-sensitive components on boards.
- Transport and store static-sensitive boards in their original containers or on conductive foam. Label any package that contains static-sensitive assemblies.
- Wear an anti-static wrist strap while handling the boards to discharge the static voltage from your body.
- Do not allow anything capable of holding or generating a static charge on the work surface.
- Do not slide a board over any surface.
- Avoid handling boards in areas that have a floor or work surface cover that is capable of generating a static charge.



---

**WARNING.** *To avoid electric shock, always power off the chassis and disconnect the power cord before cleaning or servicing the chassis.*

---

## Tools Required

Table 6–3 lists the tools needed to replace modules in the benchtop controller. All tools required to remove and install each module are listed before the procedure.

**Table 6–3: Tools required for module replacement**

Item number	Name	Description
1	Torx-drive, torque screwdriver with a T-9 tip	Standard tool
2	Small flat blade screwdriver	Standard tool
3	#0 Phillips head screwdriver	Standard tool
4	#1 Phillips head screwdriver	Standard tool
5	Diagonal cutters (to remove cable ties)	Standard tool
6	Soldering iron	Standard tool
7	Solder wick or solder removing tool	Standard tool
8	Three-sixteenth (3/16) inch nut driver	Standard tool
9	Torx-drive screwdriver with a T-10 tip	Standard tool
10	Needle nose plier	Standard tool

## Injector/Ejector Handles

You will need T-10 Torx tip driver (Table 6–3, item 9) to replace the ejector handles.

**Removal** Use this procedure and Figure 6–1 to remove the ejector handles.

---

**NOTE.** *The ejector labels can be replaced without removing the ejector handles.*

---

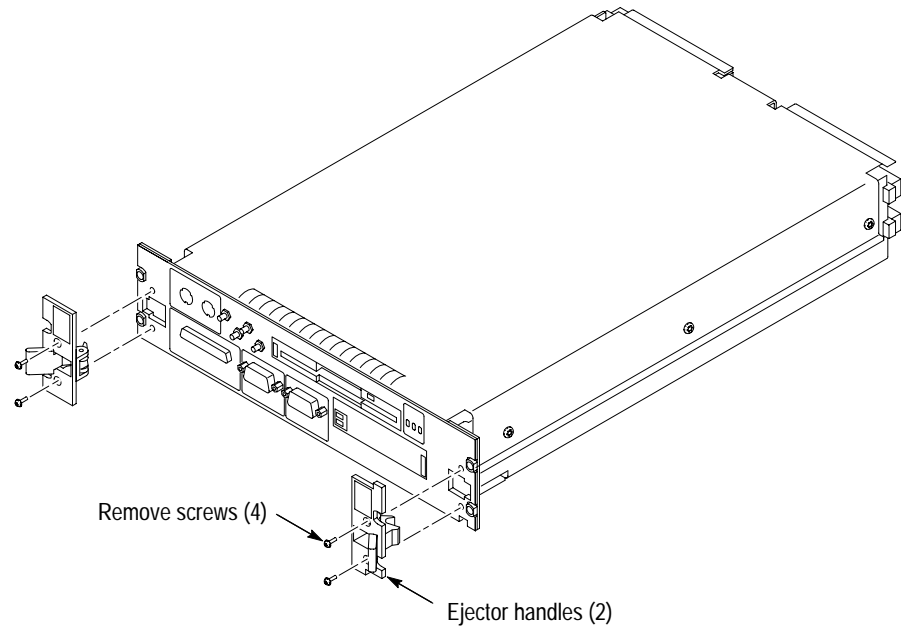

**Figure 6–1: Removal and installation of the ejectors**

1. Place the module on its right side as shown in Figure 6–1.
2. Remove the screws and flat washers that secure the ejector handle to the chassis.
3. Remove the ejector handle.

### Installation

Use this procedure and Figure 6–1 to install the ejector handles.

---

**NOTE.** *The top and bottom ejector handles are not interchangeable.*

---

1. Install the ejector handle through the front panel cutout onto the mounting post.
2. Install the screws and flat washers to secure the ejector handle to the chassis.

## Left Side Cover and Rear Panel

You will need a T-9 Torx tip driver (Table 6–3, item 1) to remove the left side cover.

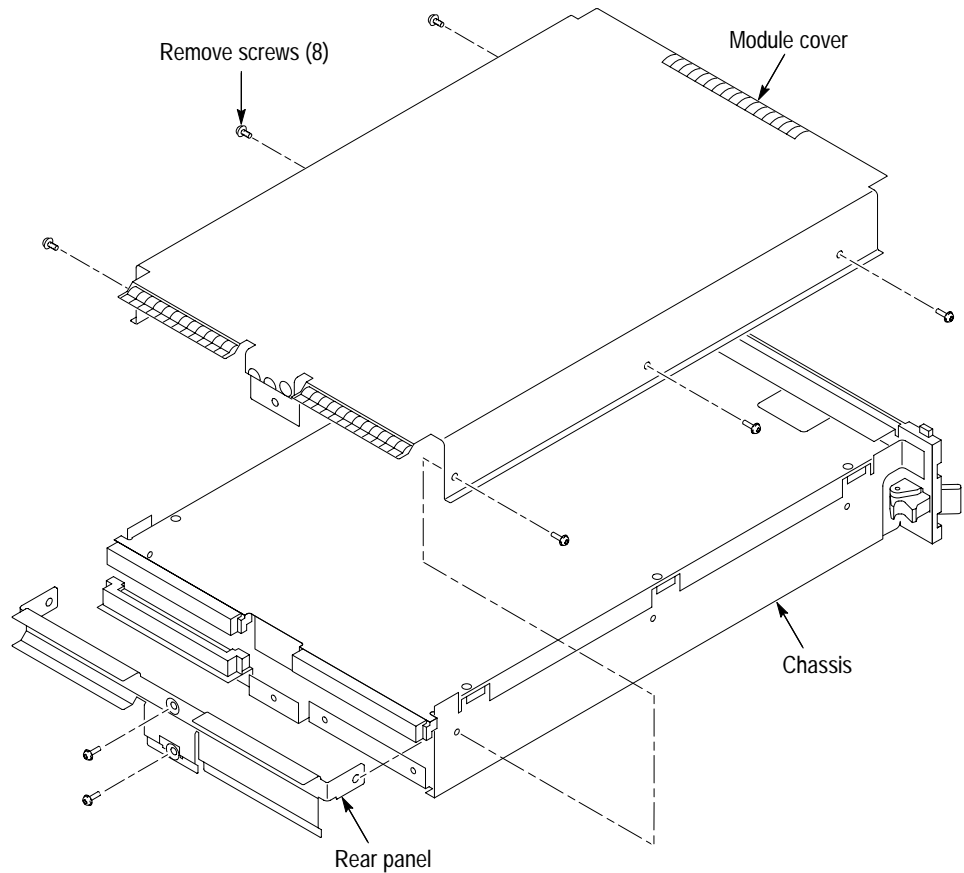

**Figure 6–2: Removal and installation of the left side cover and rear panel**

**Removal** To remove the left side cover and rear panel, refer to Figure 6–2 and follow these steps:

1. Remove the six pan head screws from the top and bottom of the enclosure. Remove the two screws from the rear panel.
2. Remove the rear panel.
3. Remove the left side cover.

**Installation** Use this procedure with Figure 6–2, and Figure 6–3 to install the left side cover:

1. Replace the left side cover.
2. Push forward on the cover so the tab on the front edge of the cover inserts into the rear of the front subpanel. Make sure that the cover is fully seated, with no gaps, against the front and rear chassis flanges.

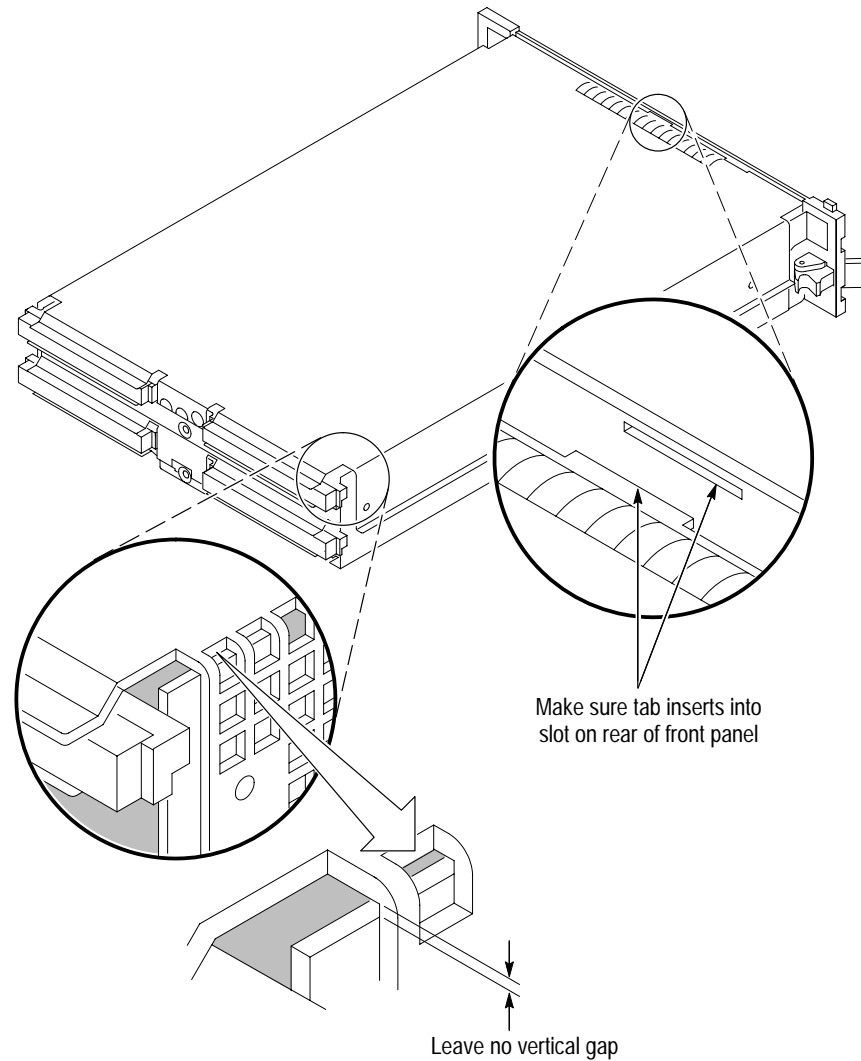

**Figure 6–3: Seating the cover on the chassis**

3. Secure the left side cover with the six T-9 Torx-drive pan head screws removed from the top and bottom of the enclosure. Tighten the screws to 4 in lbs.

4. Replace the rear panel and secure with two T-9 Torx-drive pan head screws. Tighten the screws to 4 in lbs.

## Removing the Benchtop Controller Subassembly

Remove the subassembly from the enclosure to gain access to the internal parts, such as the memory SIMMS, hard disk drive and floppy disk drive. Subassembly removal is a two part procedure. First remove the front panel hardware to relieve mechanical stress on the soldered-on connectors. Second, remove the subassembly from the enclosure.

---

**NOTE.** *Neither the subassembly nor the controller and adapter boards are replaceable individually. If faults are isolated to the subassembly boards, the entire benchtop controller must be returned to a Tektronix Service Center for repair.*

---

You will need a T-9 Torx® tip driver (Table 6–3, item 1), a small blade screwdriver (Table 6–3, item 2), a #0 Phillips head screwdriver (Table 6–3, item 3), a #1 Phillips head screwdriver (Table 6–3, item 4), a 3/16 inch nut driver (Table 6–3, item 8), and a needlenose plier (Table 6–3, item 10).

**Removal** To remove the front panel hardware refer to Figure 6–4 and Figure 6–5 and follow these steps:

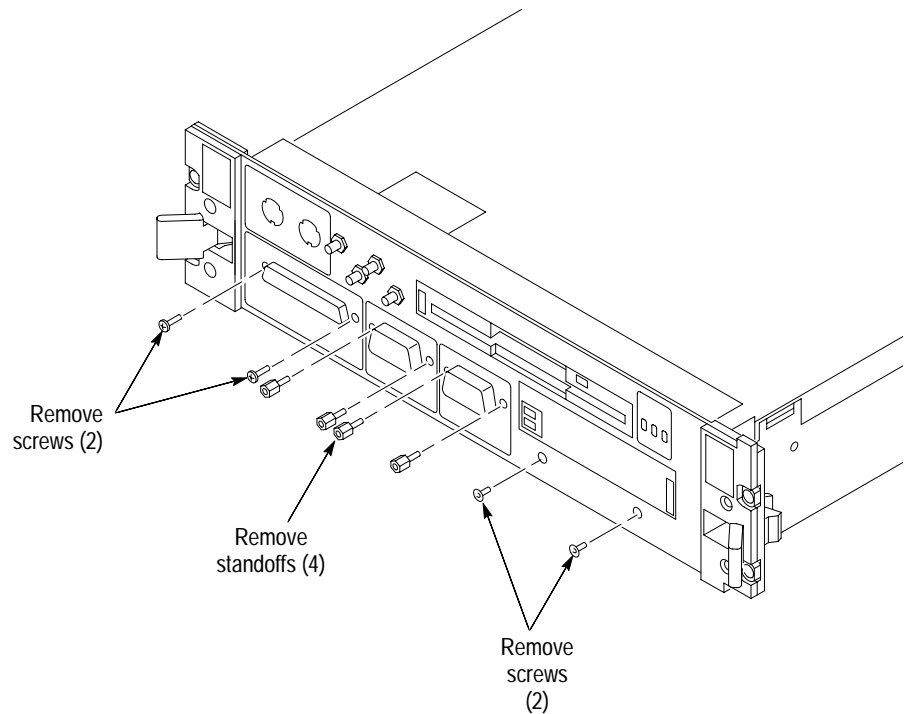

**Figure 6–4: Removal and installation of the front panel hardware**

1. Remove the four standoffs from the SVGA OUT, and COM connectors.
2. Remove the two screws from the LPT connector.
3. Remove the two flat head screws, located to the right of the PC Card slot.
4. DO NOT remove the nuts on the SMB connectors at this time.
5. Disconnect the 8-pin power cable located at the rear of the module.
6. Remove the six screws that secure the subassembly to the chassis.



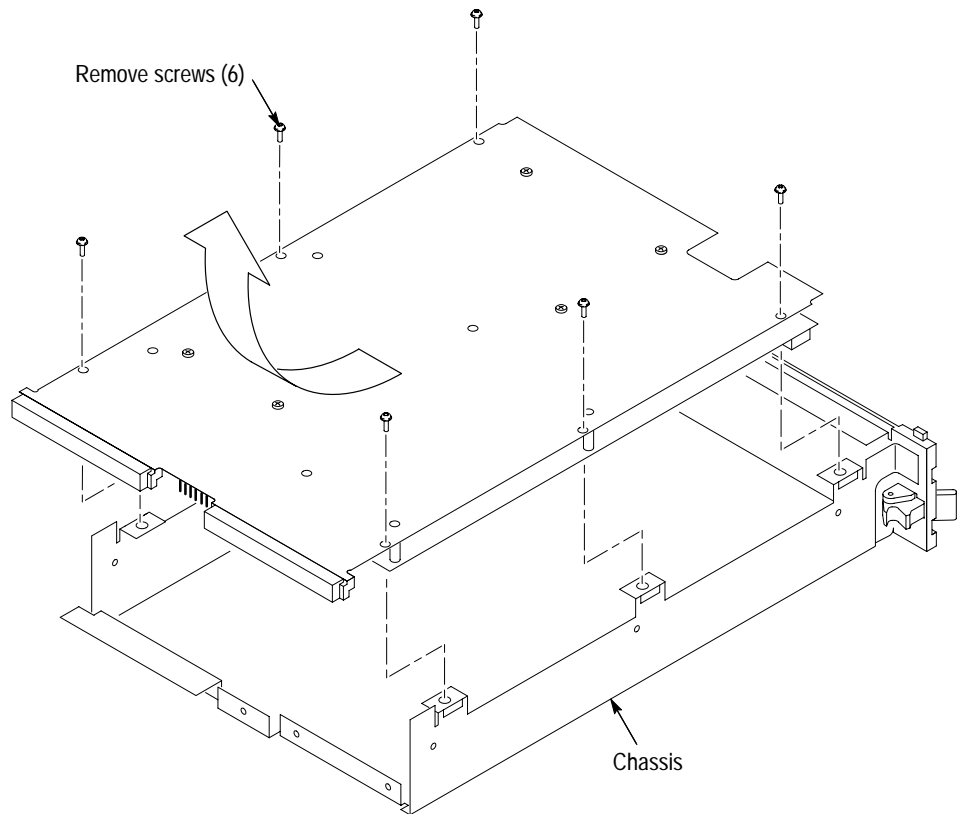

**Figure 6-5: Subassembly to chassis housing view**



**CAUTION.** The subassembly is attached to the chassis by the four SMB connector cable assemblies. Use care when lifting the subassembly out.

7. Carefully lift the subassembly part way out of the chassis.
8. Carefully turn the subassembly over and disconnect the four SMB connectors on the controller board. See Figure 6-7, and Table 6-4 for the color code placement of the four SMB cable assemblies.
9. Pass the connector assembly wires through the space between the controller board and the adapter board to remove the subassembly from the chassis.

**Installation**

To install the subassembly into the enclosure refer to Figures 6-4 and 6-5 and follow these steps:

1. Pass the connector assembly wires through the space between the controller board and the adapter board.

2. Carefully turn the subassembly over and connect the four SMB connectors on the controller board. See Figure 6–7, and Table 6–4 for the color code placement of the four SMB cable assemblies.
3. Carefully slide the subassembly into the chassis. Locate all of the front panel connectors into the proper cut-outs on the front panel.
4. Connect the 8-pin power cable located at the rear of the module.
5. Secure the six screws that secure the subassembly to the chassis. DO NOT tighten the screws until the front panel hardware has been secured.
6. Install the two flat head screws, located to the right of the PC Card slot.
7. Install the four standoffs on the SVGA OUT, and COM connectors.
8. Install the two screws on the LPT connector.
9. Tighten the six screws that secure the subassembly to the chassis.

## Memory SIMMs

### Removal

The memory SIMMs are located internally on the subassembly. Remove the Benchtop Controller subassembly from the enclosure. Refer to the section on *Removing the Benchtop Controller Subassembly* on page 6–12.

To remove the memory SIMMs, refer to Figure 6–6 and follow these steps:

1. Depress the tabs on each side of the SIMM.
2. Lift the memory SIMM out of the socket.

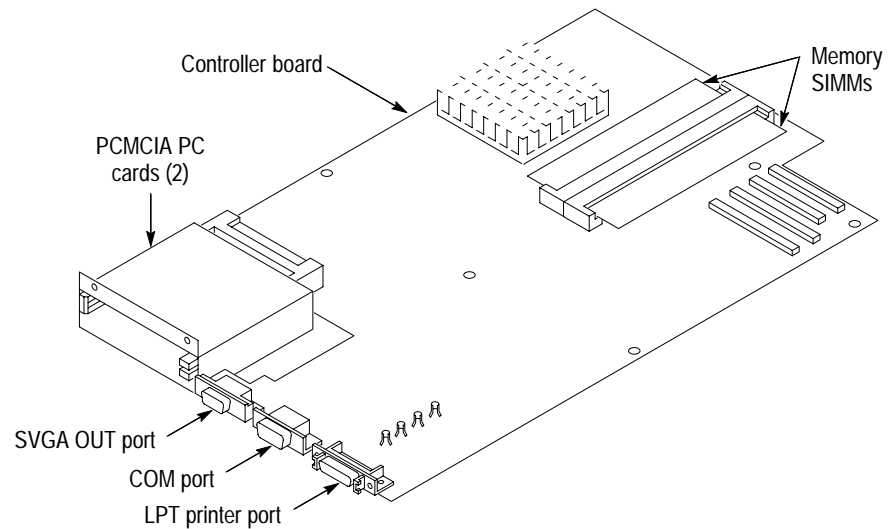

**Figure 6–6: Removal and installation of the memory SIMMs**

**Installation** To install memory SIMMs refer to Figure 6–6 and follow these steps:

1. Align the memory SIMM with the socket. Gently push the memory SIMM into of the socket.
2. The tabs on each side of the SIMM will automatically engage and lock the SIMM into place.
3. Reassemble the subassembly. Refer to the *Installation* section under *Removing the Benchtop Controller Subassembly* on page 6–12.
4. Run the QAPlus/WIN diagnostic software to verify that all of the functions of the benchtop controller are functioning correctly.

## Hard Disk Drive

**Jumper Settings** There are no jumpers required to set parameters on the hard disk drive. The absence of jumpers configure the hard disk drive as a master drive.

**Removal** The hard disk drive is located internally on the subassembly and mounted to the Adapter Board. Remove the Benchtop Controller subassembly from the enclosure, and then separate the the two boards. Refer to the section on *Removing the Benchtop Controller Subassembly* on page 6–12.

You will need a #0 Phillips head screwdriver (Table 6–3, item 3), and a #1 Phillips head screwdriver (Table 6–3, item 4).

To gain access to the hard disk drive, separate the controller board from the adapter board. Refer to Figure 6–7 and follow these steps:

1. Disconnect the two ribbon cables from the component side of the controller board. Note the location of the ribbon cables for reassembly.
2. Remove the five screws that secure the controller board to the adapter board.
3. Squeeze the two sides of the standoff located in the center of the controller board to unlatch the standoff while separating the two boards. There will be some mechanical resistance felt from the interconnections between the two boards.

Table 6–4 lists the four SMB connector signal wires and their color code identifications. Refer to Figure 6–7 for the correct location of each SMB connector.

**Table 6–4: Signal wire identification**

Signal wire color	Signal identification
White	SYSTEM TRIG IN
White/Brown stripe	SYSTEM TRIG OUT
White/Red stripe	EXTERNAL SIG IN
White/Orange stripe	EXTERNAL SIG OUT

To remove the hard disk drive, refer to Figure 6–8 and follow these steps:

1. Remove the four screws securing the hard disk drive to the solder side of the adapter board.
2. Carefully slide the hard disk drive away from the hard disk drive connector.

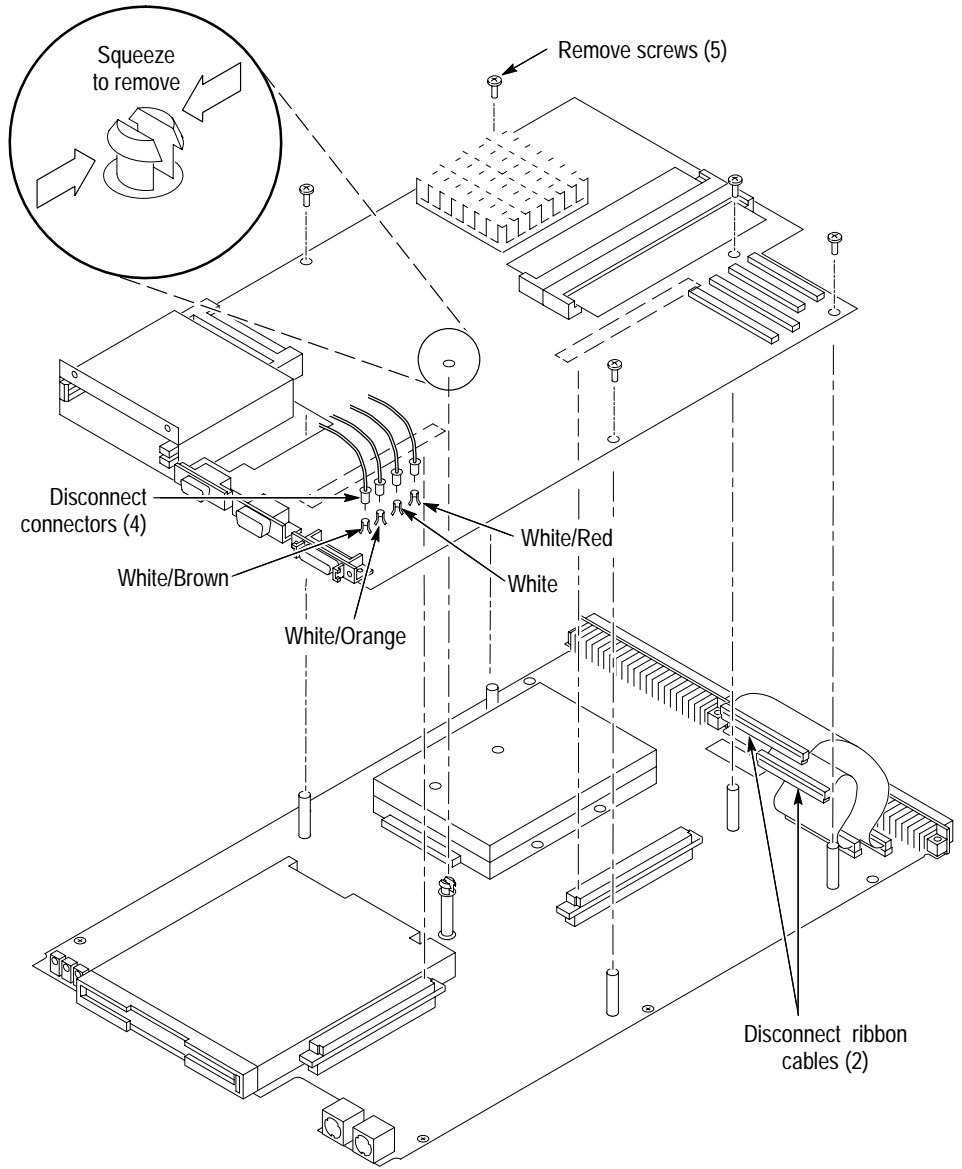
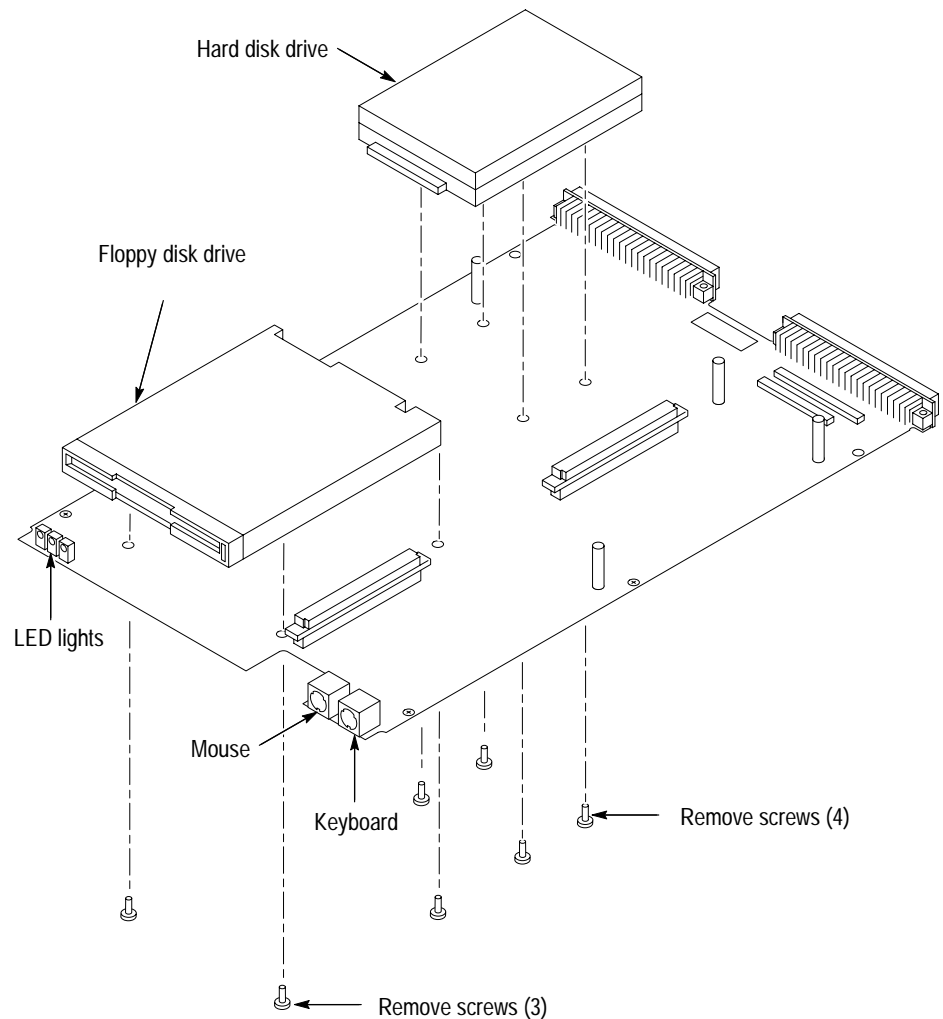

Figure 6-7: Controller board and adapter board interconnection



**Figure 6–8: Removal and installation of the disk drives**

### Installation

To install a hard disk drive you will need a #0 Phillips head screwdriver (Table 6–3, item 3), and a #1 Phillips head screwdriver (Table 6–3, item 4).

To install the hard disk drive refer to Figure 6–8 and Figure 6–7 follow these steps:

1. Carefully align the pins with the socket on the back of the hard disk drive. Gently slide the hard disk drive onto the hard disk drive connector. Verify that all of the pins are fully engaged and that no pins are bent.
2. Install the four screws to secure the hard disk drive to the adapter board.
3. Connect the two ribbon cables to the component side of the controller board. Note the location of the ribbon cables from the disassembly step.

4. Install the five screws to secure the controller board to the adapter board.
5. Reassemble the subassembly. Refer to the *Installation* section under *Removing the Benchtop Controller Subassembly* on page 6–12.
6. Reinstall all TLA software. For help on software installation, refer to the *TLA 700 Series Logic Analyzer Installation Manual*.
7. Verify that the BIOS Setup information is correct. Enter the BIOS Setup and verify the hard disk drive type and size.
8. Run the QAPLus/WIN diagnostic software to verify that all of the functions of the benchtop controller are functioning correctly.
9. Verify the CLK10 frequency and accuracy. Refer to the *TLA 700 Series Logic Analyzer Performance Verification and Adjustments Procedure Technical Reference*.

## Floppy Disk Drive

### Removal

The floppy disk drive is located internally on the subassembly, and mounted to the adapter board. Remove the subassembly from the enclosure, and then separate the two boards. Refer to section on *Removing the Benchtop Controller Subassembly* on page 6–12.

You will need a #0 Phillips head screwdriver (Table 6–3, item 3), and a #1 Phillips head screwdriver (Table 6–3, item 4).

Separate the controller board from the adapter board to gain access to the floppy disk drive. Refer to Figure 6–7 and follow these steps:

1. Disconnect the two ribbon cables from the component side of the controller board. Note the location of the ribbon cables for reassembly.
2. Remove the five screws that secure the controller board to the adapter board.
3. Squeeze the two sides of the standoff located in the center of the controller board to unlatch the standoff while separating the two boards. There may be some mechanical resistance felt from the two 96-pin interconnections between the two boards.

To remove the floppy disk drive, refer to Figure 6–8 and follow these steps:

1. Carefully remove the floppy disk drive flex ribbon cable from the connector on the component side of the adapter board.
2. Remove the three screws securing the floppy disk drive to solder side of the adapter board.

**Installation**

To install a floppy disk drive you will need a #0 Phillips head screwdriver (Table 6–3, item 3), and a #1 Phillips head screwdriver (Table 6–3, item 4).

To install the floppy disk drive refer to Figure 6–8 and Figure 6–7 and follow these steps:

1. Carefully install the floppy disk drive flex ribbon cable from the connector on the component side of the adapter board.
2. Install the three screws to secure the floppy disk drive to the adapter board.
3. Connect the controller board to the adapter board by aligning the two (2) connectors between the controller board and the adapter board. Locate the center standoff and center it on the hole on the controller board. Carefully apply pressure to both boards until the two connectors engage.
4. Connect the two ribbon cables to the component side of the controller board. Note the location of the ribbon cables from the disassembly step.
5. Install the five screws to secure the controller board to the adapter board.
6. Reassemble the subassembly. Refer to the *Installation* section under *Removing the Benchtop Controller Subassembly* on page 6–12.
7. Verify that the BIOS Setup information is correct. Enter the BIOS Setup and verify the floppy disk drive type and size.
8. Run the QAPlus/WIN diagnostic software to verify that all of the functions of the benchtop controller are functioning correctly.



## Soldered-On Connectors

**Removal and Installation** Soldered-on connectors are located internally on the subassemblies and mounted to the adapter board and the controller board. Remove the subassembly from the enclosure, then separate the two boards. Refer to section on *Removing the Benchtop Controller Subassembly* on page 6–12.

You will need a soldering iron (Table 6–3, item 6), and solder wick or a solder removing tool (Table 6–3, item 7).

The following connectors are physically soldered on to the circuit board:

- Mouse and keyboard connectors: soldered to the adapter board.
- SVGA OUT, COM, LPT connectors: soldered to the controller board.

Removing soldered on components requires that a qualified service person is skilled in the servicing of through-hole technology on printed circuit boards. Every reasonable precaution shall be made by the service person to eliminate damage to the circuit board.

# Troubleshooting



---

**WARNING.** Before performing this or any other procedure in this manual, read the General Safety Summary and Service Safety Summary found at the beginning of this manual. Also, to prevent possible injury to service personnel or damage to electrical components, please read Preventing ESD on page 6-2.

---

This section contains information and procedures designed to help you isolate faults within the benchtop controller. The process is as follows:

1. Do *Check for Common Problems* on page 6-24 to eliminate easy to find problems first.
2. Do *Eliminate Other Problem Sources* on page 6-26 to eliminate the benchtop chassis and other modules as the fault(s) source next.
3. Do *Troubleshoot the TLA 711 Color Benchtop Controller Module* on page 6-27 to locate the failed replaceable part within the module.

If you have replaced a faulty circuit board or assembly found using these procedures, you must perform any verification and adjustment procedures identified in Table 6-10 on page 6-41 for the replaced assembly or replaceable part.

## Service Level

This section supports isolation of faults within the benchtop controller to the replaceable-part level that is reflected in the replaceable part list in Chapter 10. In most cases, faults are isolated to circuit boards or assemblies, but not to individual components on those boards. (See *Strategy for Servicing* on page xiii.) Fault isolation is supported to the following replaceable parts:

- Injectors/Ejectors
- Memory SIMMs
- Hard disk drive
- Floppy disk drive
- Soldered on connectors listed on page 6-22
- Standard and optional accessories listed on page 10-1

---

**NOTE.** *The controller board and the adapter board are not replaceable parts on their own. If there is a failure of either the controller board or the adapter board, return the entire benchtop controller to a Tektronix Service Center for module exchange.*

---

## Required Documents

Other TLA 700 manuals may be required to help you isolate faults; other manuals and other sections in this manual contain instructions you will need to complete repairs after locating a faulty part. Refer to Table 6–5 for a list of required documentation.

**Table 6–5: Required documentation**

Manual or Section	Purpose
<i>TLA 711 Color Benchtop Chassis Service Manual</i>	To eliminate benchtop chassis as problem source
<i>TLA 700 Series Logic Analyzer Performance Verification and Adjustment Procedures Technical Reference</i>	To perform periodic verification and calibration, or to check and adjust after module or replaceable part replacement
<i>TLA 700 Series Logic Analyzer Installation Manual</i>	To remove and reinstall modules in the benchtop chassis To reinstall Windows95 or TLA 700 Software when required
<i>Removal and Replacement Instructions</i> (in this manual)	To remove and reinstall failed replaceable parts
<i>Replaceable Parts List</i> (in this manual)	To order replaceable parts
<i>Update the BIOS</i> (in this manual)	To update the BIOS

For a list of all manuals available for the TLA 700 Logic Analyzer, see *Related Manuals* on page vii of the *Preface* to this manual.

## Check for Common Problems

Use Table 6–6 to quickly isolate possible failures. Table 6–6 lists problems related to the benchtop controller and possible causes. This list is not exhaustive, but it may help you eliminate a problem that are quick to fix, such as a blown fuse or loose cable.

**Table 6–6: Failure symptoms and possible causes**

Symptom	Possible cause(s)
Mainframe does not power on	<ul style="list-style-type: none"> <li>■ Power connection faulty, check or substitute the power cord.</li> <li>■ Fuse blown, check the line fuse on the benchtop chassis.</li> <li>■ Benchtop chassis power supply failure, refer to the <i>TLA 711 Benchtop Chassis Service Manual</i> for troubleshooting procedures.</li> </ul>
Benchtop controller fails to boot up  Benchtop controller not operating	<ul style="list-style-type: none"> <li>■ Benchtop controller may not be not fully inserted, make sure the front of the benchtop controller is flush with front panel. Reseat the benchtop controller if necessary.</li> <li>■ Benchtop chassis power supply failure, refer to the <i>TLA 711 Benchtop Chassis Service Manual</i> for troubleshooting procedures.</li> <li>■ Corrupted module firmware, reinstall firmware. Refer to <i>Upgrading Module Firmware</i> in the <i>TLA 700 Series Installation Manual</i>.</li> </ul>
Module(s) not recognized	<ul style="list-style-type: none"> <li>■ Refer to the appropriate module(s) service manual.</li> </ul>
SYSTEM FAIL indicator is red	<ul style="list-style-type: none"> <li>■ Benchtop controller may not be not fully inserted, make sure the front of the benchtop controller is flush with front panel. Power off the benchtop chassis and reseat the benchtop controller.</li> <li>■ Follow the troubleshooting procedure and primary troubleshooting tree.</li> <li>■ Benchtop chassis or benchtop controller failure, refer to the troubleshooting procedure in this manual for the benchtop controller, refer to the <i>TLA 711 Benchtop Chassis Service Manual</i> for troubleshooting procedures for the benchtop chassis.</li> </ul>
Monitor does not power on	<ul style="list-style-type: none"> <li>■ Verify monitor power cord is plugged in.</li> <li>■ Failed fuse.</li> <li>■ Monitor failure.</li> </ul>
Benchtop controller appears to have no power	<ul style="list-style-type: none"> <li>■ Benchtop controller may not be not fully inserted, make sure the front of the benchtop controller is flush with front panel. Power off the benchtop chassis and reseat the benchtop controller.</li> <li>■ Memory SIMMs incorrectly installed, missing, or defective.</li> <li>■ Defective controller board or adapter board.</li> <li>■ Benchtop controller power connector loose or defective.</li> </ul>
Monitor display is blank (no raster)	<ul style="list-style-type: none"> <li>■ Monitor SVGA cable not connected or defective.</li> <li>■ External monitor controls (brightness) turned down.</li> <li>■ Monitor defective.</li> </ul>

**Table 6–6: Failure symptoms and possible causes (cont.)**

Symptom	Possible cause(s)
Modules not recognized	<ul style="list-style-type: none"> <li>■ Module firmware incompatible with mainframe software version. Refer to the <i>TLA 700 Series Installation Manual</i> for software and module firmware update instructions.</li> <li>■ TLA 700 system problem. Execute the internal resource manager program to determine if the mainframe recognizes any installed modules. Refer to instructions on page 6–32.</li> <li>■ Module may not be not fully inserted, make sure the front of the module is flush with front panel. Power off the benchtop chassis and reseal the module.</li> <li>■ Faulty module. Refer to appropriate module service manual for further troubleshooting information.</li> </ul>
BIOS error messages are displayed	<ul style="list-style-type: none"> <li>■ Refer to the BIOS error message table, Table 6–9 on page 6–35.</li> </ul>

## Eliminate Other Problem Sources

This module is part of the TLA 700 Series Logic Analyzer, which comprises modules and the benchtop chassis (and in this case, the benchtop controller). The following procedures will help you eliminate the benchtop chassis and other modules as possible sources of the failure(s) before you troubleshoot the benchtop controller.

### Substitute a Good Module

If you have available a known-good controller, perform the following procedure:

1. Remove the suspect benchtop controller from the benchtop chassis. The benchtop controller is a VXIbus slot zero form factor device. First verify that the benchtop controller is installed in slot zero and one (the benchtop controller is a dual-wide module).
2. Install the known-good benchtop controller in slot zero.
3. Power-on the benchtop chassis and check for normal operation.
4. If the failure symptoms are still present with the known-good benchtop controller installed, the problem is most likely in the benchtop chassis, not in the benchtop controller. Refer to the *Troubleshooting* section in Chapter 6 of your *Benchtop Chassis Service Manual*.
5. If your benchtop chassis operates normally with the known-good benchtop controller installed, then the suspect benchtop controller needs to be serviced. Refer to the *Troubleshoot the Benchtop Controller Module* on page 6–27.

**Check the Benchtop Chassis**

If you do not have a know-good controller, perform the following procedure to make sure the benchtop chassis is not the source of the failure:

- Remove all plug-in modules from the benchtop chassis except the controller.
- Run “signs of life” tests (Primary Troubleshooting Tree in Chapter 6 of the *TLA 711 Color Benchtop Chassis Service Manual*).

**Troubleshoot the Benchtop Controller Module**

Follow the procedure in this section to identify the failed part within the benchtop controller. This procedure requires that the benchtop chassis is fully functional. If you have not determined that the benchtop chassis is fully functional, refer to *Eliminating Other Problems Sources* on page 6–26.

**Equipment Required**

The basic troubleshooting procedures require no test equipment. There are no accessible test points to measure voltages or signals within the benchtop controller.

Testing and adjustments might be required to correct some faults. Under those circumstances, you will need the test equipment listed in the *TLA 700 Series Performance Verification and Adjustment Procedures* manual.

**Fault Isolation Procedure**

The fault isolation procedure for the benchtop controller consists of following the the primary troubleshooting tree in Figure 6–9.

If you are unable to identify any problems through the troubleshooting tree or through the diagnostic programs refer to *Isolating System Problems* beginning on page 6–32 for further troubleshooting information.

**Benchtop Controller Diagnostics**

The benchtop controller diagnostics consist of the following tests:

- Benchtop controller power-on BIOS test
- Power-on diagnostics
- QAPlus/WIN diagnostics
- TLA 700 Mainframe Diagnostics

**Power on BIOS test.** On power up, the benchtop controller automatically runs the power on BIOS test. If the power on BIOS test detects a problem, BIOS error(s) will be displayed. The BIOS error messages are found in Table 6–9 on page 6–35.

**Power-on Diagnostics.** The power-on diagnostics check the basic functionality of the controller and mainframe at every power on. If any failures occur at power on, the screen displays the calibration and diagnostics property page. Table 6–7 lists a subset of the power on tests. Use the results of the tests to help you isolate problems.

The power on BIOS and TLA 700 power-on diagnostic tests ensure that hardware is installed and can be accessed by the software. The tests do not provide any performance information, but they do provide limited diagnostic information. The separately invoked TLA 700 mainframe diagnostics provide more extensive tests than the power-on diagnostics.

The power on tests check the generic hardware including the keyboard, mouse, memory, CPU, and associated peripherals. The interface circuitry between the controller and the mainframe backplane is also tested. The interrupt lines and trigger lines are also tested for each installed application module.

If there are no failures, you can view the results of the tests in the Calibration and Diagnostics page under the System menu. To view the Extended diagnostics, click on the Extended tab.

**Table 6–7: TLA 700 Power-on diagnostic tests**

Component	Group & test	Power on	Extended
TLA 700 mainframe	VTC Reset Test	✓	
	VTC Walk1 Test	✓	
	ADG Register Test	✓	
	ADG VXI Addr Test	✓	
	ADG VXI Data Test	✓	
TLA 700 system	Interrupt Lines	✓	✓
	Trigger Lines	✓	✓

**QAPlus/WIN.** If the benchtop controller passes all of the BIOS tests, the primary tree will have you run QAPlus/WIN. To run QAPlus/WIN you must have either a working keyboard or a working mouse (or other pointing device) and have Windows 95 running. QAPlus/WIN is a comprehensive software application to check and verify the operation of the benchtop controller. Repair or replace any failed component identified by QAPlus/WIN.



---

**CAUTION.** Before running the QAPlus/WIN tests, be aware of the following software bugs.

---

- The QAPlus/WIN discrete memory test fails if the computer being tested contains more than 16 Megabytes of RAM.

If your computer contains more than 16 Megabytes of RAM, do not run the discrete memory test from the Memory icon. Use the Run Quick Test or Run Full Test item from the Tests menu, or use the Quick Test icon in the QAPlus/WIN title box.

- The QAPlus/WIN hard drive test reports an incorrect number of tracks and cylinders for your hard drive.

This is an internal mapping problem, but has no effect on the results of the test. Bad sectors on your hard drive are still found and marked.

- The installation program for QAPlus/WIN stalls at the end of the installation process.

To continue after the installation process stalls, press CTRL-ALT-DEL, highlight the QAPlus/WIN installation program in the resulting menu, then click on End Task.

- The QAPlus/WIN keyboard test does not respond correctly to the Windows 95-specific keys found on Windows 95 enhanced keyboards.

Keyboards made for use with Windows 95 contain two or three keys specific to that operating system. These are usually located on either side of the space bar. QAPlus/WIN does not “trap” these keys when performing the keyboard test. Do not press them.

To run the QAPlus/WIN diagnostics, do the following steps:

1. Turn off all other applications.
2. Click on START in the tool bar.
3. Select Programs from the Start menu.
4. Select Qaplusw.exe.  
(Refer to the help section in QAPlus/WIN for more information on running QAPlus/WIN).

**TLA 700 mainframe diagnostics.** If the benchtop controller passes all the QAPlus/WIN tests, the primary tree calls for you to run the TLA 700 Mainframe Diagnostics. The TLA 700 Mainframe Diagnostics are a comprehensive software test that checks benchtop chassis as well as benchtop controller functionality. If the TLA 700 Mainframe Diagnostics test fails to run correctly, the benchtop controller is defective.



To run the TLA Mainframe diagnostics, do the following steps:

1. Turn off all other applications.
2. Click on START in the tool bar.
3. Select Programs from the Start menu.
4. Select Tektronix TLA 700 from the Programs menu.
5. Select TLA 700 Mainframe Diagnostics from the Tektronix TLA 700 menu. (Refer to the help section in the TLA 700 Mainframe Diagnostics for more information on running the TLA 700 Mainframe Diagnostics).

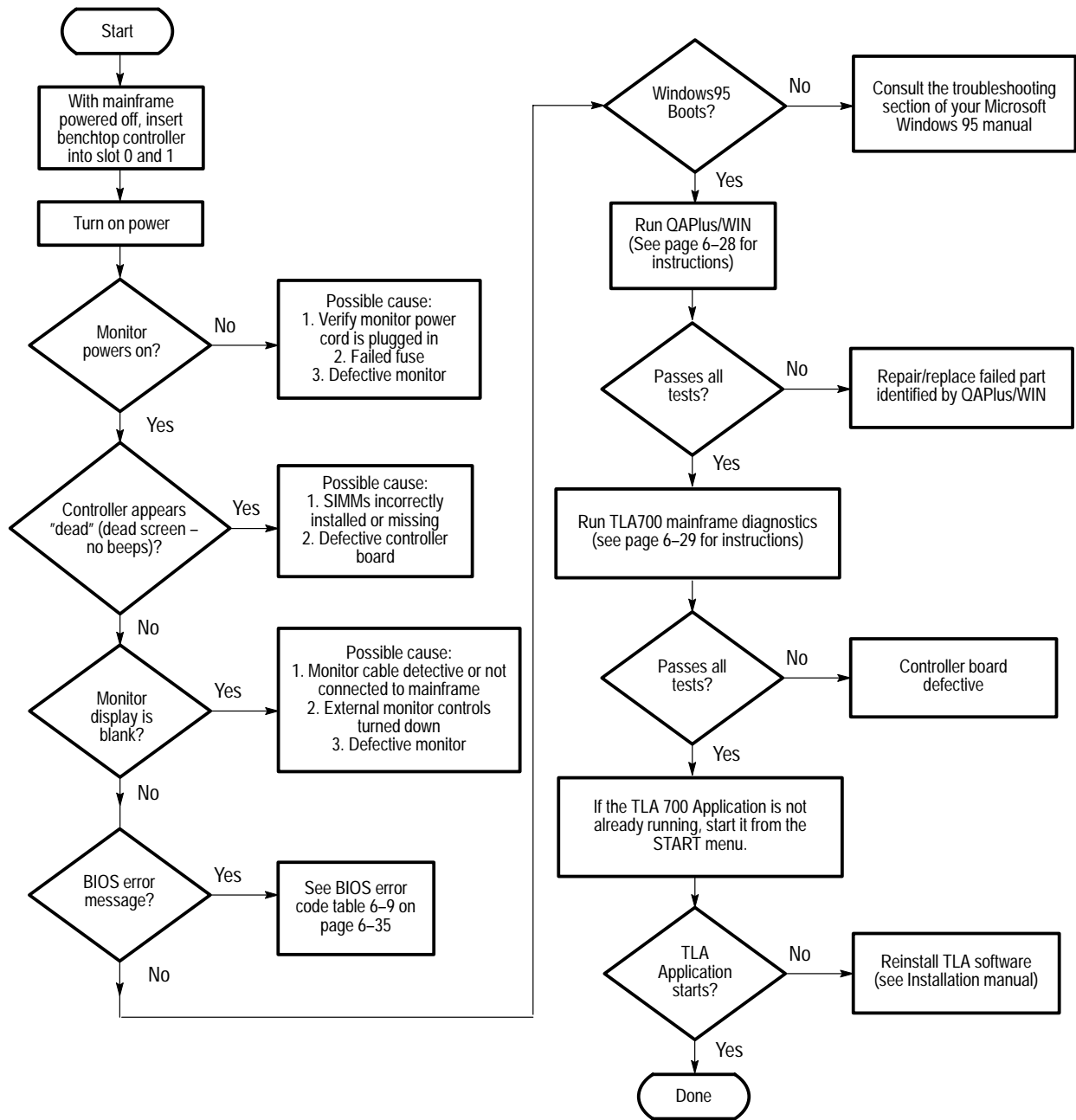

Figure 6-9: Primary troubleshooting tree

### Isolating System Problems

If you have completed all of the troubleshooting procedures up to this point and the TLA 700 application fails to display any modules in the System Window, you may have a system problem. Check for the following:

- Verify that all modules are properly installed.
- Verify that the module address switches are set correctly. Power off the mainframe and remove the modules. Set the address switches to FF and reinstall the modules.
- Verify that the modules do not have the flash programming jumper installed on the rear of the module. Power off the mainframe and remove the modules. Remove the jumper and reinstall the modules.
- Try placing a suspected module in a different slot to verify slot dependency problems. For example, if you have a single module in slots 2 and 3, power off the mainframe, move the module to slots 3 and 4, and try the tests again. If the module works in the new location, you have identified a faulty slot in the mainframe.
- Check for bent or broken pins on the backplane of the mainframe.
- Faulty module. Replace the suspected faulty module with a known-good module, or contact your local Tektronix service center.
- Incompatible module firmware and mainframe software versions. Refer to the *TLA 700 Series Installation Manual* for software and module firmware update instructions.
- Ensure that the CMOS Setup parameters are set correctly (refer to Appendix B of the *TLA 700 Installation Manual* for a list of the correct setups).
- Check for computer viruses.

You can also execute the internal resource manager program (ResMan32.exe) to identify whether each of the installed modules are being identified in the mainframe slots. Table 6–8 on page 6–33 lists some of the command line options for executing ResMan32.

**Table 6–8: Command line options for ResMan32**

Option	Description
-a, -A, -o, -O	ResMan32 will not close the text window after executing and displaying the results the major functions (default).
-p, -P	ResMan32 will not execute the mainframe power-on self test diagnostics (default).
-v, -V	ResMan32 records the resource manager actions in the text window in a short form or nonverbose mode.
+a, +A, +o, +O	ResMan32 will terminate the tests and display the resultant action information in the text window.
+p, +P	ResMan32 will perform the mainframe power-on self test diagnostics.
+v, +V	ResMan32 records all actions in a text window in the verbose mode (default).
+t, +T	ResMan32 will not display the text window and the tests will terminate after executing regardless of the error conditions.
+m, +M	ResMan32 displays in a minimized window.

To run ResMan32, perform the following steps:

1. Quit the TLA 700 application and any other applications on the desktop.
2. Click on the Window 95 Start button and select Run.
3. In the dialog box enter the following path:  
`C:\Program Files\TLA 700\System\ResMan32.exe`
4. Click on OK.

The ResMan32 program will check all of the installed modules and their address locations. The program will print out data similar to that in Figure 6–10 on page 6–34. In this example the mainframe has two logic analyzer modules installed and both modules have been successfully accessed and resources have been allocated.

If ResMan32 encounters any errors (such as an unsupported instrument or application module), the resource manager will stop further communications and display information on why or at what point the instrument module was disabled.

```
#Resource Mgr
#09/09/97 08:48:49
Auto Exit - Off
Identify Static Configure Devices
    Found a device at LA 1
    Found a device at LA 2
Identify Dynamic Configure Devices
Matching Devices to Slots
    match la=1 to slot=1
    match la=2 to slot=3
Setting VISA Attributes
    la 1, slot 1: device_class 2, manf_id 0xffd, model_code 0x7f4, addr_spc 0
    la 2, slot 3: device_class 2, manf_id 0xffd, model_code 0x7f1, addr_spc 0
Setting VISA Address Maps
    A24 device @ la 1 - starting address 200000x, size 65536
    A24 device @ la 2 - starting address 210000x, size 65536
Enabling Events & Responses
    la 1: Int ID 1 assigned to IRQ 4
    Enabling Events: 16-32 124-125 127
    la 1: Asynchronous Enable succeeded
        **Responses are unsupported by this device
    la 2: Int ID 1 assigned to IRQ 4
    Enabling Events: 16-32 124-125 127
    la 2: Asynchronous Enable succeeded
        **Responses are unsupported by this device
Begin Normal Operation
    slot 1, LA 1, started successfully
    slot 3, LA 2, started successfully
VISA Data
    la_1=1,1,4093,2036,2,0,1,7,2097152
    la_2=2,3,4093,2033,2,0,1,7,2162688
```

**Figure 6–10: ResMan32 program output**

## BIOS Error Messages

The benchtop controller runs a BIOS test on bootup. If the BIOS test encounters any problem the program displays the error on the external monitor. Table 6–9 lists the error codes, an explanation of each error code, and actions that can be taken. Refer to the *TLA 700 Series Installation Manual* for information on BIOS setup parameters and feature settings.

**Table 6–9: BIOS error codes and explanations**

Error code	Error code explanation	Action to be taken
Diskette drive A error	The BIOS test recognizes the presence of the floppy disk drive but the floppy disk drive fails the POST test. The floppy disk drive may be defined incorrectly in the CMOS setup. The floppy disk drive may not be connected correctly on the adapter board.	Verify the floppy disk drive is configured correctly in the CMOS setup. Verify that the floppy disk drive cable is connected on the floppy disk drive and the adapter board.
Extended RAM Failed at offset: nnnn	The extended memory may not be configured correctly or the extended memory is defective at HEX address nnnn.	Verify that the extended memory is configured correctly in the CMOS setup. Exchange the SIMMs, if one of the SIMMs are defective the error address should change.
Failing Bits: nnnn	The RAM address mapped to HEX nnnn in the system, shadow, or extended memory has failed. A 1 in the map indicates a failed bit.	Exchange the SIMMs, if one of the SIMMs are defective the error address should change.
Fixed Disk 0 Failure (or) Fixed Disk Controller Failure	The hard disk drive may not be defined correctly in the CMOS setup. The hard disk drive may not be connected correctly. The hard disk drive may be defective.	Verify the hard disk drive is configured correctly in the CMOS setup. Verify that the hard disk drive cable is connected on the hard disk drive and on the adapter board.
Incorrect Drive A Type – run Setup	The floppy disk drive may not be defined correctly in the CMOS setup	Verify the floppy disk drive is configured correctly in the CMOS setup.
Invalid NVRAM media type	The BIOS can not access the NVRAM	Replace the memory SIMMs. Replace the benchtop controller module.
Keyboard controller error	The keyboard controller may be defective	Swap keyboard with a known good keyboard. Replace the benchtop controller module.
Keyboard error	The keyboard may be missing or defective	Swap keyboard with a known good keyboard.
Keyboard error nn	There may be a stuck or defective key. The BIOS returns the address of the key where HEX nn is the address of the key	Swap keyboard with a known good keyboard.
Monitor type does not match CMOS – Run SETUP	The monitor type may be defined incorrectly in SETUP	Verify that the monitor type is defined correctly in the CMOS setup
Operating system not found	The operating system can not be found.	Insert a bootable disk into the floppy disk drive and try to reboot. Reload the Windows 95 operating system.

**Table 6–9: BIOS error codes and explanations (cont.)**

Error code	Error code explanation	Action to be taken
Parity Check 1	A parity error was found on the communications bus. The BIOS will return the address of the error or display ???? if it cannot.	There may be a bad connection between the benchtop controller and the Benchtop Chassis, or the benchtop controller is not installed at slot zero and one. Turn the power off, remove the benchtop controller. Inspect the connectors on the rear of the benchtop controller. Install the benchtop controller into slot zero and one. Apply power and re-test.
Parity Check 2	A parity error was found on the I/O bus. The BIOS will return the address of the error, or display ???? if it cannot.	The controller board may be defective. Replace the benchtop controller.
Press <F1> to resume, <F2> to Setup	This message is displayed after a recoverable error message.	This is a information message. Press the <F1> key to restart the boot process, or press the <F2> key to enter the CMOS setup and make changes to the definitions. Verify that the CMOS setup is configured correctly.
Press <F2> to enter SETUP	This is an optional message that can be turned on and off in CMOS setup. It is only displayed during a POST test.	This is a information message.
Previous boot incomplete – Default configuration used	The previous POST test was not successful. If the POST test fails, POST will load default values then display a message to run the CMOS setup. If incorrect values are loaded, future boot attempts may fail.	This is an information message. Verify that the CMOS setup is configured correctly.
Real time clock error	The real time clock may be defective.	The controller board may be defective. Replace the benchtop controller.
Shadow Ram Failed at offset: nnnn	The shadow RAM has failed at Hex location nnnn.	The system will run without shadow RAM, but it will run slow. Exchange the SIMMs, if one of the SIMMs are defective the error address should change.
System battery is dead – Replace and run SETUP	The CMOS clock may be dead or disconnected. The CMOS setup may have to be reset.	The system battery is internal to the RAM/Calendar component. To replace the system battery, replace the RAM/Calendar component. <b>Note:</b> After replacing the RAM/Calendar component, you must reflash the BIOS. Refer to <i>Update the BIOS</i> on page 6–37 and perform the procedures to reflash the BIOS.
System BIOS shadowed	The system BIOS was copied to shadow RAM.	This is an informational message. No action needs to be performed.
System cache error – Cache disabled	When the system BIOS failed the cache test the cache was disabled.	The system will run without cache RAM, but it will run slow. Reboot the system.
System CMOS checksum bad – run SETUP	The system CMOS settings may be incorrect or modified incorrectly by some application. The CMOS setup may have to be redefined.	This is an information message. Reboot the system first, then verify that the CMOS setup is configured correctly.

**Table 6–9: BIOS error codes and explanations (cont.)**

<b>Error code</b>	<b>Error code explanation</b>	<b>Action to be taken</b>
System RAM Failed at offset: nnnn	The system RAM at HEX address nnnn may be defective.	Exchange the SIMMs. If one of the SIMMs are defective the error address should change.
System timer error	The BIOS failed the timer test. The controller board may be defective.	Try rebooting the system first. If this message keeps reappearing the benchtop controller is defective. Replace the benchtop controller.

## Update the BIOS Version

On rare occasions it may be necessary to update the controller BIOS version. In most cases this is only necessary to activate enhancements to the product. To update the BIOS, you will need the latest version of BIOS available on floppy disk (Tektronix part number 063-2895-xx). Before updating the BIOS verify that the BIOS version on the instrument is an older version than that printed on the floppy disk label.

### Verify the BIOS Version

The BIOS version is briefly displayed on boot up of the instrument. To verify the BIOS version number, power on the instrument and watch the upper left hand section of the screen. A message will be displayed as below:

Copyright 1996 By RadiSys Corporation. Version 1.xx.xx.  
RadiSys boot block version 1.xx.xx

Before continuing, verify that the BIOS version that is displayed is an older version than the version you are installing.

### Verify the BIOS Jumper is in Place

Some controllers were shipped with the BIOS jumper already in place. If the jumper is not in place, you must disassemble the controller and install the jumper.

If the BIOS jumper is not in place, you will get an error message stating that the BIOS could not be updated. In order to continue, you must disregard the message and power off the instrument. Continue with the following steps to disassemble the controller and install the jumper. After installing the jumper, you must repeat the BIOS flash procedure.

If the jumper is in place continue with the procedure *Set Up and Update the BIOS* on page 6–39.



### Install the BIOS Jumper

To install the BIOS jumper, perform the following procedures to disassemble the controller to access the jumper location:

1. If you have not already done so, power off the instrument and remove the power cord.
2. Disconnect the mouse, keyboard, external monitor, and any other cables or connectors to the controller.
3. Remove the controller from the mainframe and set it on a clean working surface.
4. Follow the procedure beginning on page 6–10 to remove the left side cover and rear panel.
5. Follow the procedures beginning on page 6–12 to remove the benchtop controller subassembly.
6. Place a shorting jumper at jumper position H2, pins one and three. Refer to Figure 6–11 for the jumper placement.

The BIOS jumper does not need to be removed after the BIOS is updated.

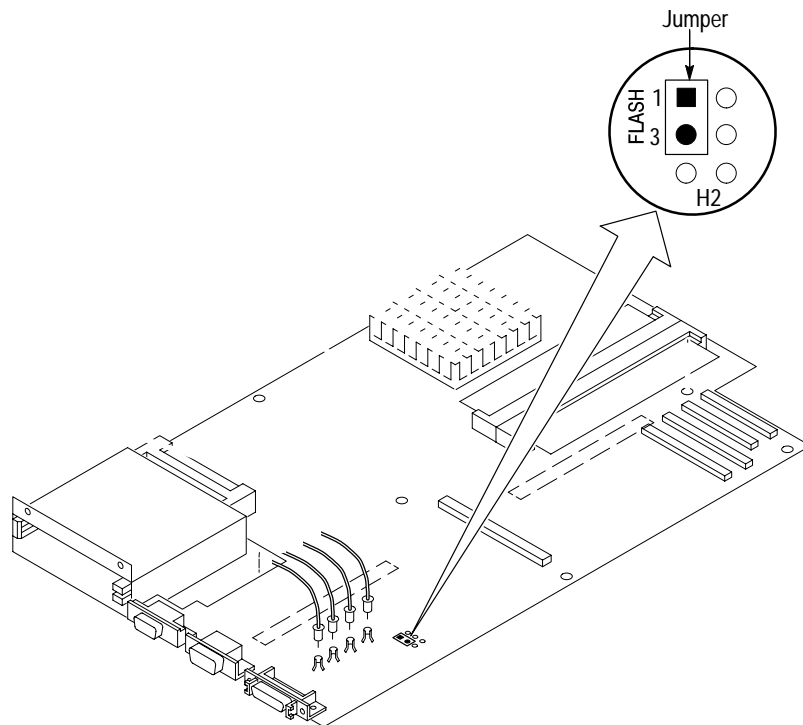

Figure 6–11: Controller board and adapter board interconnection

7. After installing the BIOS jumper, reassemble the controller module.
8. Reinstall the controller in the mainframe and reconnect all connectors removed earlier.
9. Reconnect the power cord to the benchtop chassis.

### Set Up And Update the BIOS

The new BIOS requires you to change the CMOS BIOS settings. This only has to be done once. To change the CMOS BIOS settings, follow these steps:

1. Insert the BIOS software floppy disk into the disk drive.
2. Power the instrument on. The floppy disk is a bootable floppy.
3. At the A:\> prompt, type phlash and press the Return key.
4. When the install program completes, press any key at the prompt.
5. Remove the floppy disk from the floppy disk drive.

### Configure the CMOS Setup and Complete the Setup

Perform the following steps to configure the BIOS CMOS setup. You may want to refer to the *TLA 700 Series Installation Manual* for a complete list of the parameters for the CMOS setup.

1. Power the instrument off, and then on.
2. During the boot up process, press function key F2 to enter the CMOS Setup.  
  
You may see a Checksum Error message. This is because you have not yet configured the CMOS setup.
3. Select Continue from the menu to load the default values.
4. In the CMOS setup main menu select IDE Adapter 0 Master and then select Autotype for the hard disk drive type.
5. Enter the Advanced menu and scroll to the Advanced Chipset Control submenu and select it by pressing the Return key.
  - a. Set the DRAM memory speed to 60 ns.
  - b. Press the Esc key to exit the Advanced Chipset Control submenu.
6. Select Exit and then select Save.
7. Continue with the regular boot up of the instrument.
8. Double-click on the My Computer icon.
9. Double-click on the Control Panel icon.
10. Double-click on the Add New Hardware icon.

11. Click Next> to continue.
  - a. When the popup prompts you: Do you want Windows to search for your new hardware, click Yes [Recommended].
  - b. Click Next> to proceed, and click Next> again to confirm that you want to continue.
  - c. The Add New Hardware Wizard will take a few minutes to complete the task.
12. When the Add New Hardware Wizard completes its task, click the Details button and verify that Advanced power management support is listed.
13. Click Finish, and exit the Add New Hardware Wizard.
14. In the Control Panel, double click on the Power icon.
15. Verify that there is a Power tab present in Power Properties.
16. Verify that Allow Windows to manage power use on this computer is checked. If it is not checked, click on the little box to place a check mark there.
17. Click Advanced...

Verify that the Show suspend command on Start menu is not checked. If it is checked, click on it to remove the check mark.
18. Close the Power Properties text box, and close the Control Panel.
19. Close out your Windows session by selecting Shut Down... from the Windows menu.
20. The instrument will close your Windows session and automatically power off.

### Verify Operation

Run the QAPlus/WIN diagnostic software to verify that all of the functions of the benchtop controller are functioning correctly.

After running the QA/Plus/WIN diagnostics, quit the application by selecting Restart MS Windows, and clicking the OK button. This guarantees that the TLA 700 returns to a stable state for normal operation.

## Adjustment After Repair

After the removal and replacement of a circuit board or assembly due to failure, locate the circuit board or assembly removed in Table 6–10 and perform the indicated procedures. The adjustment and calibration/certification procedures are found in the *TLA 700 Series Performance Verification and Adjustment Procedures* manual.

**Table 6–10: Requirements after replacement**

Board replaced	Adjustment required	Verification checks
Controller board	CLK 10 Time base accuracy verification/recertification	Refer to the <i>TLA 700 Series Performance Verification and Adjustment Procedures</i> manual.
Adapter board	None required	Run QAPlus/WIN
Hard disk drive See note below	None required See note below	Run QAPlus/WIN
Floppy disk drive	None required	Run QAPlus/WIN
Memory SIMMs	None required	Run QAPlus/WIN

**NOTE.** *If the hard disk drive is replaced, all of the software must be reloaded with the backup media supplied with your logic analyzer. The hard disk drive listed in the replaceable part section does not come with any software preloaded on it.*

*Refer to the TLA 700 Series Logic Analyzer Installation Manual for more information on loading software.*



## Repackaging Instructions

If you need to send the benchtop controller to a Tektronix field center for repair, attach a tag to the benchtop controller with the owners name, address, and phone number, along with the serial number, and a detailed description of the problem(s) encountered or the service required.

Always return all accessories so that the entire system can be tested.

When repacking the benchtop controller for shipment, use the original packaging. If the packaging is unavailable or unfit for use, contact your local Tektronix representative to obtain new packaging.







# Options

This chapter lists the advertised options for the TLA 711 Color Benchtop Mainframe. Refer to the *Replaceable Mechanical Parts* chapter for a list of standard and optional accessories for the chassis.

Tektronix offers maintenance options that cover calibration and repair services. Contact your local Tektronix representative for details.

Tektronix will ship the options shown in Table 7–1:

---

**NOTE.** Service options are listed on the Tektronix Service Options page that precedes the Table of Contents in this manual.

---

Table 7–1: Options





	Option #	Label	Description
	1S	Sub MF Kit	32 MB DRAM / 2.16 GByte Hard Disk Drive Upgrade Delete: Controller with 16 MByte DRAM / 840 MByte HDD Add: Controller with 32 MByte DRAM / 2.16 GByte HDD Note: All current TLA 700 Series software installed on HDD (Windows 95 SW, QA Plus SW, and TLA 700 Applications software; Windows 95 manuals also included) Note: The storage capacities of DRAM and Hard Disk Drive (HDD) are valid at introduction, and are continually subject to change due to the fast-moving PC component environment. Consult a Tektronix Sales Representative for the current capacities.
	1A	Add LAN PC Card	10BaseT and 10Base2 Add: LAN Package
	1M	Add 17 inch Monitor	Add: 17" color monitor (includes 5' monitor cable) Same 15A power cord ordered with TLA 711
	2M	Add 21 inch Monitor	Add: 21" color monitor (includes 5' monitor cable) Same 15A power cord ordered w/TLA 711
	1K	Add LACART	Add LACART

Table 7-1: Options (Cont.)

	Option #	Label	Description
	A1	Universal European power cord	220 V, 50 Hz, 16A power cord Delete standard power cord
	A2	UK power cord	240 V, 50 Hz, 13A power cord Delete standard power cord
	A3	Australian power cord	240 V, 50 Hz, 10A power cord Delete standard power cord
	A4	North American power cord	240 V, 60 Hz, 15A power cord Delete standard power cord
	A5	Switzerland power cord	220 V, 50 Hz, 10A power cord Delete standard power cord
	95	Add Cal Report	Add: Cal (Test Data) Report



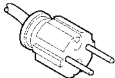
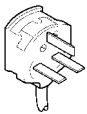

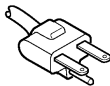
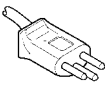
# Electrical Parts List

Refer to the *Mechanical Parts List* chapter for descriptions of replaceable parts for the TLA 711 Color Benchtopy Controller.





# Diagrams

## Controller Board Block Diagram

The controller board is a personal computer (PC) controller utilizing standard Intel Pentium-AT architecture.

The controller board has a PCI to PCMCIA PC card host adapter that is used to control the two PCMCIA PC card slots.

The controller board has one external SVGA port. The controller board has one ECP/EPP Centronics compatible parallel port, and one external serial RS232 COM port to support standard PC based I/O peripherals.

Figure 9-1 shows the controller board block diagram.

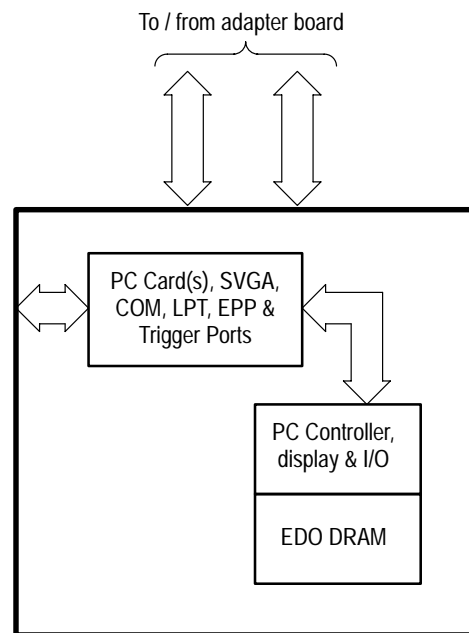

Figure 9-1: Controller board block diagram

## Adapter Board Block Diagram

The adapter board provides both electrical and mechanical support to the controller board. The adapter board acts as the distribution point for all of the electrical power for the module.

The adapter board supports the hard disk drive, floppy disk drive, keyboard and mouse ports, PC speaker, decoding and buffering to the communications bus.

Figure 9–2 shows the adapter board block diagram.

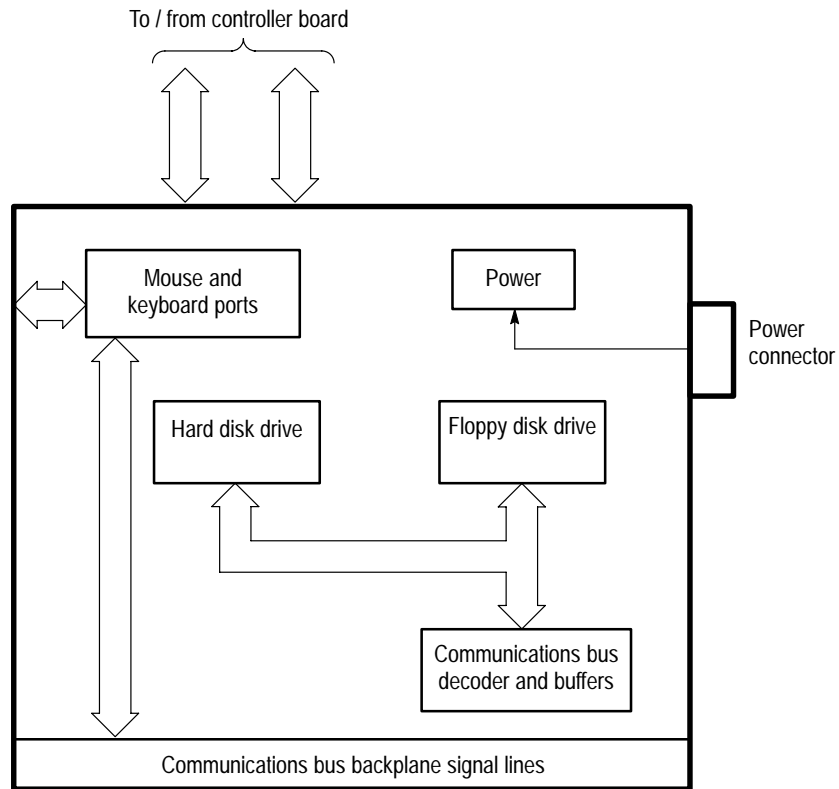

Figure 9–2: Adapter board block diagram





# Replaceable Mechanical Parts

This chapter contains a list of standard accessories, optional accessories, and replaceable parts for the benchtop controller, and the benchtop mainframe. You can use this information to identify and order accessories and replacement parts.

After the benchtop controller is mated to the benchtop chassis, the resulting combination is the benchtop mainframe. The standard accessories and the optional accessories listed in this section are for the benchtop mainframe.

Refer to the *Replaceable Parts List* for replaceable parts that are specific to the benchtop controller.

## Standard Accessories

The benchtop mainframe comes standard with the accessories listed in Table 10–1.

**Table 10–1: Standard accessories**

Accessory	Part number
102-key Windows 95 Keyboard (US), PS2 mini DIN	119-5193-00
Tek Mouse, 3-button, PS2 mini-DIN	119-4330-01
Dual-wide Slot Panel Fillers (5)	333-4206-00
Single-wide Slot Panel Filler	333-4205-00
SMB-to-BNC cable (2)	P6041
Female-to-Female BNC Used for mainframe diagnostics	103-0028-00
Printer Adapter Cable, 3 feet	012-1512-00
Windows 95 Package (Microsoft software and manual)	Not applicable
QAPlus/WIN SW	063-2506-00
TLA System Software	063-1967-00
TLA 700 Application Software	063-1967-00
TLA 700 Application Software Update Kit	020-3001-XX
Jumper with pull-tab (used for flashing module FW)	131-4356-00
TLA 700 User Manual	070-9775-00
TLA 700 Installation Manual	070-9774-00
Certificate of Traceable Calibration	NA

**Table 10–1: Standard accessories (cont.)**

Accessory	Part number
Power Cord, North American, 120 V/60 Hz., 13A	161-0213-00
Power Cord, North American, 120 V/60 Hz., 15A	161-0218-00
Fuse, 6.3A	159-0381-00
Fuse, 20A	159-0379-00
TLA 711 Shipping List	NA
Tek Mouse Pad	Order by description

## Optional Accessories

For a list of options, refer to chapter seven, *Options*.

You can also order the optional accessories listed in Table 10–2.

**Table 10–2: Optional Accessories**

Accessory	Part number
RS-232 Serial Interface Cable	012-1241-00
TLA 711 Benchtop Mainframe Rackmount Kit	020-2197-00

## Parts Ordering Information

Replacement parts are available through your local Tektronix field office or representative.

Changes to Tektronix products are sometimes made to accommodate improved components as they become available and to give you the benefit of the latest improvements. Therefore, when ordering parts, it is important to include the following information in your order.

- Part number (see Part Number Revision Level below)
- Instrument type or model number
- Instrument serial number
- Instrument modification number, if applicable

If you order a part that has been replaced with a different or improved part, your local Tektronix field office or representative will contact you concerning any change in part number.

Change information, if any, is located at the rear of this manual.

**Part Number Revision Level**

Tektronix part numbers contain two digits representing the revision level of the part. For most parts in this manual, you will find the letters XX in place of the revision level number.



When you order parts, Tektronix will provide you with the most current part for your product type, serial number, and modification (if applicable). At the time of your order, Tektronix will determine the part number revision level needed for your product, based on the information you provide.

**Module Servicing**

Modules can be serviced by selecting one of the following options. Contact your local Tektronix service center or representative for repair assistance.

**Module Repair and Return.** You may ship your module to us for repair, after which we will return it to you.

**New Modules.** You may purchase replacement modules in the same way as other replacement parts.

## Using the Replaceable Parts List

The rest of this chapter contain lists of the replaceable mechanical and/or electrical components of the Portable Mainframe. Use these lists to identify and order replacement parts. The following table describes each column in the lists.

**Table 10-3: Parts lists column descriptions**

Column number	Column name	Description
1	Figure and Index Number	Figure and index numbers in the exploded view illustrations.
2	Tektronix Part Number	Use this part number when ordering replacement parts from Tektronix.
3 and 4	Serial Number	Column 3 indicates the serial number at which the part was first effective. Column 4 indicates the serial number at which the part was discontinued. No entries in either column indicates the part is good for all serial numbers.
5	Qty	Quantity of parts used.
6	Name and Description	An item name is separated from the description by a colon (:). Because of space limitations, an item name may sometimes appear incomplete. Use the U. S. Federal Catalog Handbook H6-1 for further item name identification.
7	Mfr. Code	Manufacturer code.
8	Mfr. Part Number	Manufacturer's or vendor's part number.

### Abbreviations

Abbreviations conform to American National Standard ANSI Y1.1-1972.

### Mfr. Code to Manufacturer Cross Index

The table titled Manufacturers Cross Index shows codes, names, and addresses of manufacturers or vendors of components listed in the parts list.

## Manufacturers Cross Index

<b>Mfr. Code</b>	<b>Manufacturer</b>	<b>Address</b>	<b>City, State, Zip Code</b>
06383	PANDUIT CORP	17303 RIDGELAND AVE	TINLEY PARK, IL 60477-3048
0B445	ELECTRI-CORD MFG CO INC	312 EAST MAIN STREET	WESTFIELD, PA 16950
OJ9P4	DELTA ENGINEERING & MFG. CO.	19500 SW TETON	TUALATIN, OR 97062
OKB01	STAUFFER SUPPLY CO	810 SE SHERMAN	PORTLAND, OR 97214-4657
OKB05	NORTH STAR NAMEPLATE INC	5750 NE MOORE COURT	HILLSBORO, OR 97124-6474
0L0L7	RADISYS CORPORATION	5445 NE DAWSON CREEK DRIVE	HILLSBORO, OR 97124
0VF15	TOTAL TECHNOLOGIES LTD	2110 S ANNE ST	SANTA ANNA, CA 92704
OZQ35	3COM CORPORATION	5353 BETSY ROSS DRIVE	SANTA CLARA, CA 95052-8145
1GM54	ZYTEC CORP	7575 MARKET PLACE DR	EDEN PRAIRIE, MN 55344
24931	BERG ELECTRONICS INC	BERG ELECTRONICS RF/COAXIAL DIV 2100 EARLYWOOD DR PO BOX 547	FRANKLIN, IN 46131
26742	METHODE ELECTRONICS INC	BACKPLAIN DIVISION 7444 WEST WILSON AVE	CHICAGO, IL 60656-4548
2W733	BELDEN WIRE & CABLE COMPANY	2200 US HWY 27 SOUTH PO BOX 1980	RICHMOND, IN 47374
2W944	PAPST MECHATRONIC CORP	AQUIDNECK INDUSTRIAL PARK	NEWPORT, RI 02840
50356	TEAC AMERICA INC	7733 TELEGRAPH RD PO BOX 750	MONTEBELLO, CA 90640-6537
51506	ACCURATE SCREW MACHINE CO	19 BALTIMORE ST	NUTLEY, NJ 07110-1303
52152	3M COMPANY	INDUSTRIAL TAPE DIVISION 3M CENTER	ST PAUL, MN 55144-1000
5F520	PANEL COMPONENTS CORP	PO BOX 115	OSKALOOSA, IA 52577-0115
60128	MICROSOFT CORPORATION	ONE MICROSOFT WAY DEPARTMENT 101	REDMOND, WA 98052-8300
61081	ELECTRONIC SOLUTIONS	6790 FLANDERS DR	SAN DIEGO, CA 92121
63426	NKK SWITCH	NIHON KAIHEIKA IND CO LTD 7850 E GELDING DRIVE	SCOTTSDALE, AZ 85260
71400	BUSSMANN	DIVISION COOPER INDUSTRIES INC PO BOX 14460	ST LOUIS, MO 63178
75915	LITTELFUSE INC	800 E NORTHWEST HWY	DES PLAINES, IL 60016-3049
7X318	KASO PLASTICS INC	11013 A NE 39TH	VANCOUVER, WA 98662
80009	TEKTRONIX INC	14150 SW KARL BRAUN DR PO BOX 500	BEAVERTON, OR 97077-0001
80126	PACIFIC ELECTRICORD CO	747 WEST REDONDO BEACH PO BOX 10	GARDENA, CA 90247-4203
8X345	NORTHWEST SPRING MFG CO	5858 WILLOW LANE	LAKE OSWEGO, OR 97035
S3109	FELLER U.S. CORPORATION	72 VERONICA AVE UNIT #4	SOMERSET, NJ 08873
TK2208	NORTHWEST RUBBER EXTRUDERS INC	16748 SW 72ND AVE	PORTLAND, OR 97224
TK2469	UNITREK CORPORATION	3000 LEWIS & CLARK HWY SUITE 2	VANCOUVER, WA 98661
TK2541	AMERICOR ELECTRONICS LTD	UNIT-H 2682 W COYLE AVE	ELK GROVE VILLAGE, IL 60007

### Replaceable Part List

There are three replaceable part listings. The first list contains replaceable parts and accessories common to both the MIN and MAX configurations, as well as the benchtop mainframe. The second replaceable part list contains parts that are specific to the MIN configuration. The third replaceable part list contains parts that are specific to the MAX configuration.

### Replaceable parts list

Fig. & Index Number	Tektronix Part Number	Serial No. Effective	Serial No. Discont'd	Qty	Name and Description	Mfr. Code	Mfr. Part Number
10-1							
-1	348-1365-01			1	SHLD GSKT,ELEC:SYMETRICAL SLOTTED FINGER,0.350 W X 7.5 L,RIVIT MTG,SNAP-IN,RIVIT SPACING 1.5 IN	TK2647	0493-0069-01
-3	-			6	SCREW,MACHINE:4-40 X 0.250 PHILLIPS,PNH	80009	ORDER BY DESCRIPTION
-5	214-4762-00			2	SPRING,CONICAL:SPRING,CONICAL,TLA7L1	8X345	ORDER BY DESCRIPTION
-6	367-0484-00			1	HANDLE,EJECTOR:INJECTOR/EJECTOR ASSEMBLY,TWO WIDE VXI,W/OUT KEYING,SPRING LOADED,PLASTIC,20% GL	80009	367-0484-00
-7	334-9189-00			1	MARKER IDENT:EJECTOR LABEL, BOTTOM	80009	334918900
-8	367-0489-00			1	HANDLE:INJECTOR/EJECTOR ASSEMBLY,TWO WIDE VXI,WITH TTL KEYING,SPRING LOADED,PLASTIC,10%	80009	367-0489-00
-9	334-9236-00			1	MARKER IDENT:MKD, TOP INJECTOR/EJECTOR LABEL	80009	334923600
-10	Order by Mfr Part Number			1	CONNECTOR, SUB-MINIATURE, LPT SERIAL PORT	0L0L7	40-0272-01
-11	Order by Mfr Part Number			1	CONNECTOR, 9-PIN, RS-232, MALE	0L0L7	40-0019-00
-12	Order by Mfr Part Number			1	CONNECTOR, 15-PIN, SVGA, OUTPUT A	0L0L7	40-0030-00
-13	Order by Mfr Part Number			1	CABLE HARNESS, PELTOLA TO SMB (SET OF FOUR)	0L0L7	44-0162-01
-14	Order by Mfr Part Number			4	CONNECTOR, PELTOLA TO SMB	0L0L7	40-0388-00
-15	119-5528-01	B010100	B010285	1	FLOPPY DISK DRIVE, 3.5 INCH, 1.44 MBYTE	NA	NA
-15	119-5677-00	B010286		1	FLOPPY DISK DRIVE, 3.5 INCH, 1.44 MBYTE	NA	NA
-16	Order by Mfr Part Number			1	CONNECTOR, MINIATURE-DIN, KEYBOARD	0L0L7	40-0049-00
	Order by Mfr Part Number			1	IC, REAL TIME CLOCK WITH BATTERY BACKUP	0L0L7	74-0192-00
	063-2895-XX			1	SOFTWARE PACKAGE, FLASH BIOS, (PART OF 020-3001-XX)	80009	ORDER BY DESCRIPTION
	119-4330-02			1	TEK MOUSE, 3-BUTTON, PS2 MINI-DIN		
	119-5193-00			1	KEYBOARD,ASSY:WINDOWS 95 SOLUTION KEYBOARD WITH 4-PIN MINI DIN CONNECTOR	80009	119-5193-00
	159-0379-00			1	FUSE,CARTRIDGE:20A,250V,5 SEC MIN @ 200%,0.25 X 1.25,UL REC,326020,	75915	326 020

Replaceable parts list (Cont.)

Fig. & Index Number	Tektronix Part Number	Serial No. Effective	Serial No. Discont'd	Qty	Name and Description	Mfr. Code	Mfr. Part Number
	159-0381-00			1	FUSE,CARTRIDGE:5 X 20 MM,6.3A,250V,FAST BLOW,HIGH BREAKING CAPACITY,UL REC,SEMKO,	71400	GDA-6.3
	063-1967-00			1	SOFTWARE PACKAGE : APOLLO SYSTEM SOFTWARE, 3.5 FLOPPY (1.44 MEG)	80009	063-1967-00
	070-9773-XX			1	MANUAL, TECH: SERVICE, TLA711 BENCHTOP CHASSIS	80009	070-9773-XX
	070-9775-XX			1	MANUAL, TECH: USER, TLA 700 SERIES LOGIC ANALYZER, DP	80009	070-9775-XX
	070-9774-XX			1	MANUAL, TECH: TECHNICAL TLA 700 SERIES LOGIC ANALYZER INSTALLATION MANUAL	80009	070-9774-XX
					<b>OPTIONAL ACCESSORIES</b>		
	161-0066-09			1	CA ASSY,PWR:3,0.75MM SQ,250V/10A,99 INCH,STR,IEC320,RCPT,EUROPEAN	2W733	ORDER BY DESCRIPTION
	161-0066-10			1	CA ASSY,PWR:3,1.0 MM SQ,250V/10A,2.5 METER,STR,IEC320,RCPT X 13A,FUSED UK PLUG(13A FUSE),UNI	TK2541	ORDER BY DESCRIPTION
	161-0066-11			1	CA ASSY,PWR:3,1.0MM SQ,250V/10A,2.5 METER,STR,IEC320,RCPT,AUSTRALIA	80126	ORDER BY DESCRIPTION
	161-0066-12			1	CA ASSY,PWR:3,18 AWG,250V/10A,98 INCH,STR,IEC320,RCPT X NEMA 6-15P,US	S3109	ORDER BY DESCRIPTION
	161-0154-00			1	CA ASSY,PWR:3,1.0MM SQ,250V/10A,2.5 METER, STR, IEC320,RCPT,SWISS	5F520	86515030
	119-5510-00			1	LAN PC CARD:ETHERNET PCMCIA ADAPTER W/CE MARK, 3COM ETHERLINK III LAN PC CARD, 10 BASE-T & 1 (OPTION 1A ONLY)	0ZQ35	3C589
	119-5430-00			1	DISPLAY,MONITOR:17 INCH,COLOR,30-86KHZ MULTI SYNC, 0.27MM DOT PITCH,FLAT CRT,PWR SAVING (OPTION 1M ONLY)	80009	119-5430-00
	119-5422-00			1	DISPLAY,MONITOR:21 INCH COLOR MULTI-SYNC MONITOR, 30-95 KHZ, (OPTION 2M ONLY)	80009	119-5422-00
	070-9773-XX			1	MANUAL,TECH:SERVICE,TLA711 BENCH TOP CHASSIS,DP	80009	070-9773-XX
	070-9776-XX			1	MANUAL,TECH:TECHNICAL REFERENCE,TLA700 SERIES PERFORMANCE VERIFICATION AND ADJUSTMENT,DP	80009	070-9776-XX
	070-9777-XX			1	MANUAL,TECH:SERVICE,TLA704 PORTABLE MAINFRAME,DP	80009	070-9777-XX
	070-9778-XX			1	MANUAL,TECH:SERVICE,TLA711,BENCHTOP CONTROLLER,DP	80009	070-9778-XX
	070-9779-XX			1	MANUAL,TECH:SERVICE,TLA7LX/TLA7MX SERIES LOGIC ANALYZER MODULE,DP	80009	070-9779-XX
	070-9780-XX			1	MANUAL,TECH:SERVICE,TLA7D1,TLA7E1 DIGITIZING OSCILLOSCOPE MODULE,DP	80009	070-9780-XX



**Replaceable parts list – MIN configuration specific**

Fig. & Index Number	Tektronix Part Number	Serial No. Effective	Serial No. Discont'd	Qty	Name & Description	Mfr. Code	Mfr. Part Number
10-1	039-0032-00	B010100	B010285	1	BENCHTOP CONTROLLER ASSY – MIN CONFIGURATION		039-0032-00
	039-0032-01	B010286	B010489	1	BENCHTOP CONTROLLER ASSY – MIN CONFIGURATION		039-0032-01
	039-0032-02	B010490	B010529	1	BENCHTOP CONTROLLER ASSY – MIN CONFIGURATION		039-0032-02
	039-0032-03	B010530		1	BENCHTOP CONTROLLER ASSY – MIN CONFIGURATION		039-0032-03
-2	119-5588-00	B010100	B010489	1	HARD DISK DRIVE, 840 MBYTE	NA	NA
-2	119-5683-00	B010490		1	HARD DISK DRIVE, 1.4 GBYTE	NA	NA
-4	156-7501-00			2	IC, MEMORY: CMOS, DRAM, 2MEG X 32,60NS,EDO,5 VOLT, ST1322004A-60G, 72-PIN SIMM, GOLD PLATED	6Y440	ST1322004A-60G

**Replaceable parts list – MAX configuration specific (Option 1S)**

Fig. & Index Number	Tektronix Part Number	Serial No. Effective	Serial No. Discont'd	Qty	Name & Description	Mfr. Code	Mfr. Part Number
10-1	039-0039-00	B010100	B010285	1	BENCHTOP CONTROLLER ASSY – MAX CONFIGURATION		039-0039-00
	039-0039-01	B010286	B010489	1	BENCHTOP CONTROLLER ASSY – MAX CONFIGURATION		039-0039-01
	039-0039-02	B010490	B010527	1	BENCHTOP CONTROLLER ASSY – MAX CONFIGURATION		039-0039-02
	039-0039-03	B010528		1	BENCHTOP CONTROLLER ASSY – MAX CONFIGURATION		039-0039-03
-2	119-5607-00			1	HARD DISK DRIVE, 2.16 GBYTE	NA	NA
-4	156-7503-00			2	IC, MEMORY: CMOS, DRAM, 4MEG X 32, 60NS, EDO, 5 VOLT, MT8D432G-6X, 72-PIN SIMM, GOLD PLATED	6Y440	MT8D432G-6X

For a list of standard and optional accessories, refer to page 10-1.

For a list of options, refer to chapter seven, *Options*.

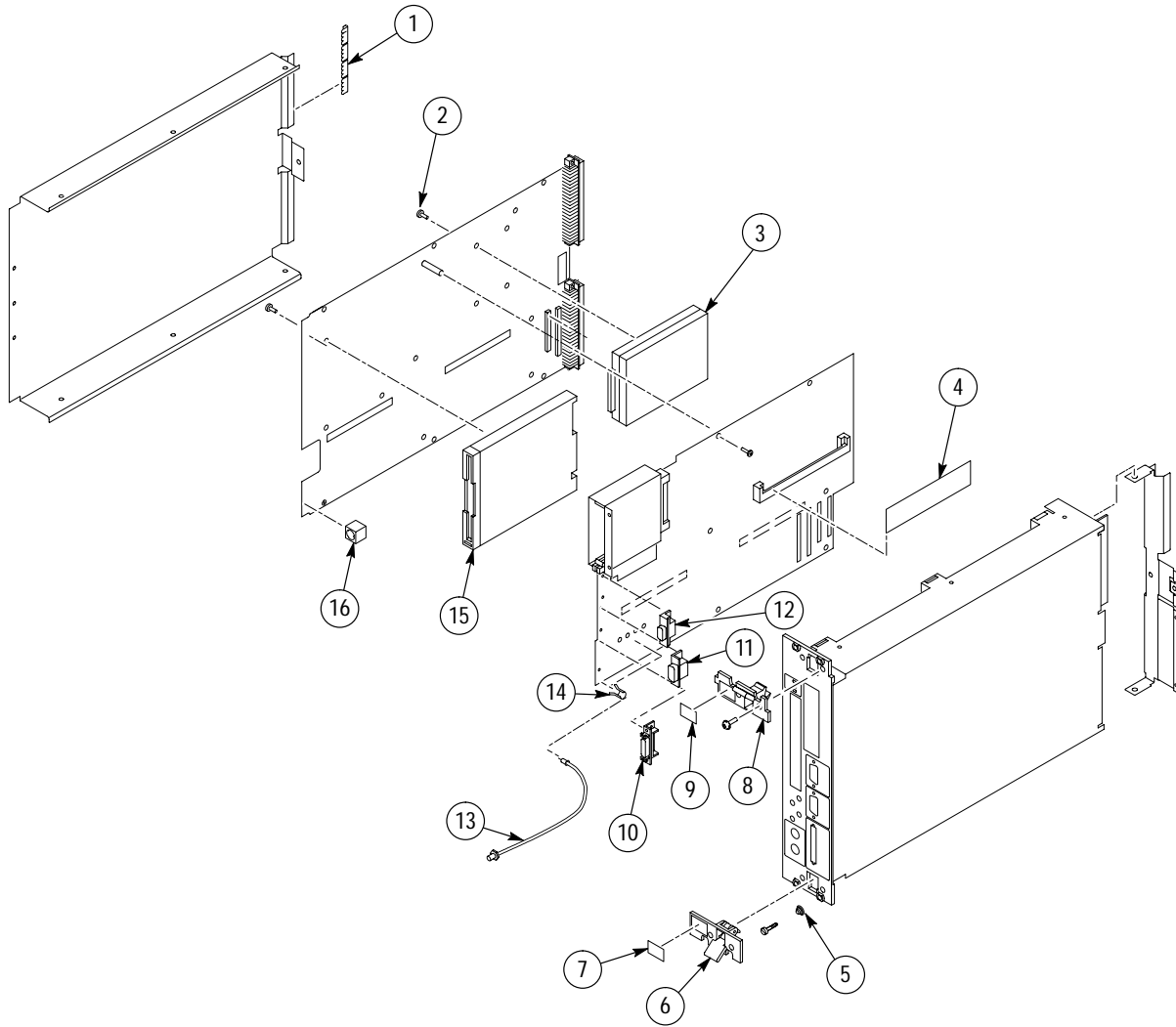

Figure 10-1: Benchtop controller exploded view





